



# Architectural Binder Section HSW75

## HSW75 — Frameless Single Track Sliding System

The HSW75 all glass single track sliding system offers clean-lined, transparent solutions with no vertical profiles for retail storefronts, shopping centers, banks, offices, and many other applications. The all glass aesthetic works well with all design styles. HSW75 creates a barrier free storefront allowing for immediate engagement between retailers and their customers. In offices, the HSW75 is well suited for flexible space management while allowing natural daylight to move throughout the interior space.

The German engineered roller system ensures quiet, smooth, and easy single-hand operation by using an “intelligent” guiding system. With the single track sliding design, stacking options, and minimal parking bays can be designed with total customization. A patented 2-in-1 release system allows for easy and quick conversion of a sliding panel into a swing door or vice versa.

### Exterior Capabilities

HSW75 can be used in exterior applications (with non-conditioned interior spaces) with varying glass thicknesses to meet design wind load requirements. Tempered glass is available up to 1" (25 mm). HSW75 unit with additional locking and with 1/2" (12 mm) tempered glass and unit height of 8' 8" (2650 mm) was independently tested per ASTM E330 and achieved design pressures of +/- 30 psf.

### Single Track Sliding for Limitless Layout Flexibility

Offering complete design flexibility, the single track sliding design is able to create an unlimited span of top hung panels which are able to easily navigate with single handed operation. HSW75 is available in various configurations from standard stacking to Window Door Combination, 90° Open Corner, True Radius or Segmented Curves, T-intersection, and 4-Way Stop.

### Customizable Stacking Options for Space Management

To optimize space management or to solve unique design challenges, stacking options, and minimal parking bays can be designed with total customization.

### 3 15/16" Continuous Rail for Outstanding Aesthetics

The HSW75 system comes standard with a 3 15/16" (100 mm) continuous top and bottom horizontal rail – even on single action sliding panels – allowing for a beautiful aesthetic and maximum glass. Customized rail options are available in

increments of 3/16" (5 mm) from 5 1/4" (133 mm) to 7 13/16" (198 mm).

To meet ADA requirements, two options are offered: a 10" (254 mm) bottom rail or a 4 3/4" (120 mm) chamfer bottom rail.

### Intelligent Rollers for Single Hand Operation

The unique “intelligent” rollers and guide technology ensure for easy, trouble-free single hand operation. The rollers are designed using hardened steel ball bearings with glass fiber reinforced polyamide wheels with memory effect and polyamide bumpers for quiet and smooth operation.

### Taller Heights and Wider Widths

Standard HSW75 comes in sizes up to 4' 1" (1250 mm) in width and 10' 6" (3200 mm) in height for sliding panels. For all single action sliding panels, sizes available are up to 3' 3" (1000 mm) in width and 10' 6" (3200 mm) in height. For single/double action end panels (non-sliding), sizes available are up to 3' 7" (1100 mm) in width and 10' 6" (3200 mm) in height. Contact NanaWall Systems for larger sizes.

### Increased Acoustical Buffering

HSW75 creates a good see-through acoustical barrier. For acoustically rated, all glass system, please see the PrivaSEE™ system.

### Single/Double Action End Panels (Non-sliding)

End panels can be single/double action panels with pivot points or single action panels with offset hinges that are capable of opening 180°. Single/double action panels have passed 500,000 cycle testing per AAMA 920.

### Single Action Panels That Can Slide Away

The single track sliding all glass wall offers the option of selective panels that convert from sliding to pivoting for convenient swinging entrance/egress doors almost anywhere within the span of the opening in order to meet your traffic pattern requirements. Pivot panels are available as single action sliding panels.

A pair of either single or double action swing panels can be added to function similarly to French doors. Single action sliding panels have passed 500,000 cycle testing per AAMA 920.

### **Patented (Patent No. US19541758) Release System Converting Single Action Sliding Panels to Pivot and Vice Versa**

The HSW75 has a patented 2-in-1 release system which combines the fixing and locking mechanism for single action sliding doors. This patent improves the handling of turning the single action door into a sliding panel in a quick two step process.

### **Concealed Automatic Interlock**

For straight units, the automatic floor bolt is self-activated by simply moving the panels on to one another. Once the first panel is positioned, the following panel activates the wheel and ramp assembly to automatically release the floor bolt, effectively locking the panel into place without the need to lock it manually. No kneeling is required.

### **Concealed Interlock**

An additional interlock option is a concealed interlock that is foot activated for straight units and for units with angle changes up to 12°. The panel to panel interlock provides additional security to the operator, assuring that the panels are locked firmly in place before they engage.

### **Other Locking**

All single action sliding panels are equipped with a quick release floor bolt with spring loaded security at the pivot end of the panel on the interior of the system. All single action sliding panels and single/double action end panels can be equipped with the same quick release floor bolt, foot activated floor bolt, or a mortise key/key cylinder lock at the swing end of the panel on the interior. For additional security on the single/double action end panels, a crank handle operated surface mounted bolt can be added at the top rail.

An additional locking option is the Locking Ladder Pull brushed stainless steel finish handle/locking system. Locking Ladder Pull integrates a locking mechanism with a profile cylinder at hand height into the tubular designed handle eliminating the need to kneel to lock at the bottom rail.

Where concealed interlocking between panels is not possible, then the quick release floor bolt with spring loaded security feature, foot activated floor bolt, mortise key/key cylinder, or a SFIC adapter is used.

### **Adjustable Eccentric Floor Sockets for Changes in Site Conditions**

To receive the floor bolts, standard to the HSW75 are eccentric floor sockets. The built-in adjustability helps to deal with tolerances and building settlements. Optional high heel resistant inserts are available.

### **Door Closer, Panic, Chamfer Rail, and Kickplate**

For single action sliding panels and single action end panel, an appropriate top door closer is provided. Optional floor closer for single/double action end panels are available.

Chamfer rail, panic device, and higher kickplate are possible.

### **Push/Pull Handles**

HSW75 offers custom made brushed stainless steel finish door pull options with built-in bumpers to protect against metal-to-glass contact. Other material options, such as matte or polished brass, are also available. ADA-complaint push/pull handles are available. Please contact NanaWall for more details.

If requested, NanaWall Systems will also prep the glass to accept door pulls provided by others in order to match project specific designs.

### **True Radius Track for Curved Units**

With the HSW75, to meet the needs of specific designs and to improve smooth operation, a true curved radius track, is available for gentle angle changes and ease of installation.

### **Reduction of Glass-to-Glass Contact**

Standard to all sliding panels, recessed polyamide bumpers are added to the end caps at the top and bottom of one side of the panel to reduce metal-to-metal or glass-to-glass contact. The H-profile, h-profile, and edge protector protect the glass edges with a light transmission (LT) factor of 74%.

For additional protection, please contact NanaWall Systems for further options.

### **Matching End Caps**

For added aesthetic value, smooth end caps in coordinating colors are used. The encompassed design of the end caps eliminates any sharp edges of the horizontal rails. End caps come with bumpers on one end of the panel. For corner panels, the end caps can be mitered to match.

### Differential Deflection

To meet the IBC 2403.4 code for larger panels with 1/2" (12 mm) glass, H-profile is standard between sliding panels. An edge protector is supplied for a single action sliding panel or single action end panel adjacent to a sliding panel.

### Finishes

Available standard door rail finish is clear anodized. Options include: brushed anodized, dark bronze anodized, black anodized, stainless steel (polished or brushed), polished brass, and satin brass. Custom colors and standard RAL colors are also an available option. For installations in need of greater corrosion resistance, the post assembly is available in clear anodized finish. To match the ceiling, recessed head track is offered with powder coat RAL 9016 Traffic White finish.

The standard exterior surface finish for the normally recessed head track is clear anodized. However, it is also available in other anodized finishes, including brushed anodized, or powder coated.

### Glazing

Standard glass thickness supplied is 1/2" (12 mm) tempered or laminated. Other glass options of up to 1" (25 mm) are available and include both laminated and tempered glass. All glass options are miter cut, creating a clean finish. The glass thickness is determined by customer need, panel size, and local code requirements. The standard rail thicknesses of 1 7/16" (36 mm) for 1/2" (12 mm) glass will be adjusted accordingly for other glass thickness. All vertical edges of the glass panels come polished. To reduce glass stress, glass is clamp installed for equal distribution of weight.

An optional white interlayer can be added for the closed panels to be used in a similar manner as a white board. Additional glazing options include low iron or colored interlayer, decorative glass, acrylic, wooden, or stainless steel mesh inserts.

### Brush Seals

All upper horizontal continuous door rails come standard equipped with an adjustable sealing brush on the outside of the unit. Options to add brush seals to both sides as well as spring loaded brushes to the bottom rail are available.





### Optional Sidelites, Fixed Panels, All Glass Folding, or Center Pivot Systems

When required, coordinating fixed panels and sidelites are available to complete the intended design.

Frameless center pivot folding CSW75 and frameless folding FSW75 are also available as mix and match systems.

# Performance Results

## HSW75

TYPE OF TEST	RESULTS									
 <p><b>Structural Load Deflection</b> <sup>①</sup> ASTM E-330</p> <p><b>With 1/2" (12 mm) thick tempered glass and additional locking (Not applicable for standard HSW75 unit)</b></p> <p><i>Note that the structural test pressures were 50% higher than the design pressures. See Design Windload Chart for other sized panels.</i></p>	<p><b>DESIGN PRESSURE</b></p> <table border="0" style="width: 100%; text-align: center;"> <tr> <td style="width: 50%;">Positive</td> <td style="width: 10%; border-left: 1px solid black;"></td> <td style="width: 40%;">Negative</td> </tr> <tr> <td>@ <b>30</b> psf</td> <td></td> <td>@ <b>30</b> psf</td> </tr> <tr> <td>(1436 Pa)</td> <td></td> <td>(1436 Pa)</td> </tr> </table> <p>Panel Height: 8' 4" (2540 mm)</p>	Positive		Negative	@ <b>30</b> psf		@ <b>30</b> psf	(1436 Pa)		(1436 Pa)
Positive		Negative								
@ <b>30</b> psf		@ <b>30</b> psf								
(1436 Pa)		(1436 Pa)								
 <p><b>Forced Entry Resistance</b> <sup>①</sup> AAMA 1304</p>	<p>Pass</p>									
 <p><b>Operating Force</b> <sup>①</sup> ASTM E-2068</p>	<p>HSW75 meets:</p> <ul style="list-style-type: none"> <li>• Sliding Panel: Initiate Motion - 1.5 lbf (7 N) &amp; Maintain Motion - 1 lbf (4 N)</li> <li>• Single/Double Action End Panel: Initiate Motion - 1 lbf (4 N) &amp; Maintain Motion - 1 lbf (4 N)</li> <li>• Single Action Sliding Panel: Initiate Motion - 1 lbf (4 N) &amp; Maintain Motion - 1 lbf (4 N)</li> </ul>									
 <p><b>Cycle Testing</b> <sup>①</sup> AAMA 920</p>	<p>Swing panels — both single/double action end panel and single action sliding panel — 500,000 cycles: Pass</p>									

<sup>①</sup> Excerpts of results of four panel units of size 12' 0" W x 8' 8" H (3676 mm x 2642 mm) with 1/2" (12 mm) thick tempered glass and additional locking (for structural load deflection) for one unit being three sliding panels and a single action end panel; and one unit with two sliding panels, single action sliding panel, and a single action end panel tested by Architectural Testing, Inc., Fresno, CA, an independent testing laboratory in November 2016.

# Design Windload Chart | HSW75 With Additional Locking

**Applies to Negative Design Pressure and Positive Design Pressure with Adjustable Eccentric Floor Socket**  
 (In Accordance with Allowable Stress Design (ASD) Design Pressures\*)

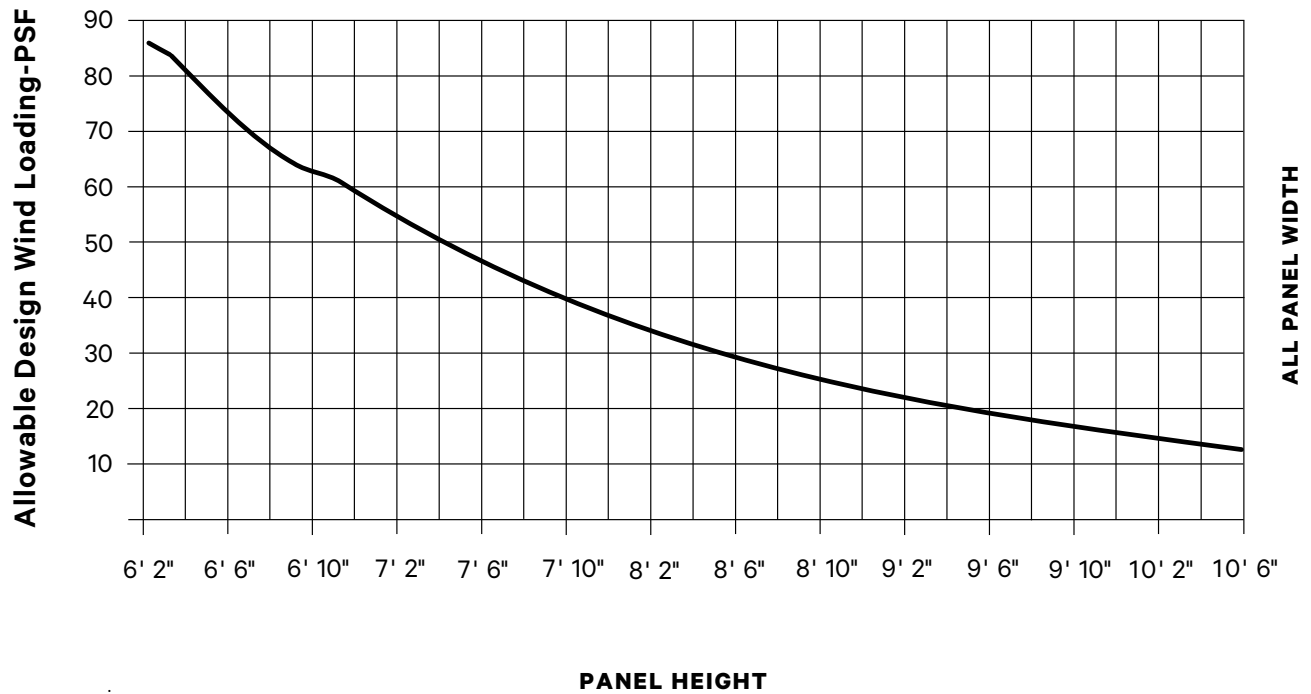

**Any Custom Size is Possible. See Maximum Frame Size Chart for Possible Sizes.**  
**HSW75 with Additional Locking with 1/2" (12 mm) Tempered Glass**

(Derived from both Glass Strength and Deflection Comparative Analysis). Test Panel Height: 8' 4" (2540 mm)  
 Please note that some jurisdictions may limit the use of these charts or may not accept them at all. Design pressures and/or sizes may be restricted to what was tested. This chart is only applicable for units with referenced NanaWall supplied locking.

\* If the project design pressures have been calculated in accordance with Ultimate Design Wind Speed (ULT), then these design pressures have to be multiplied by a factor of 0.6 to obtain the equivalent ASD design pressures shown in this chart.

### Maximum Size Chart for HSW75 with Different Panel Types

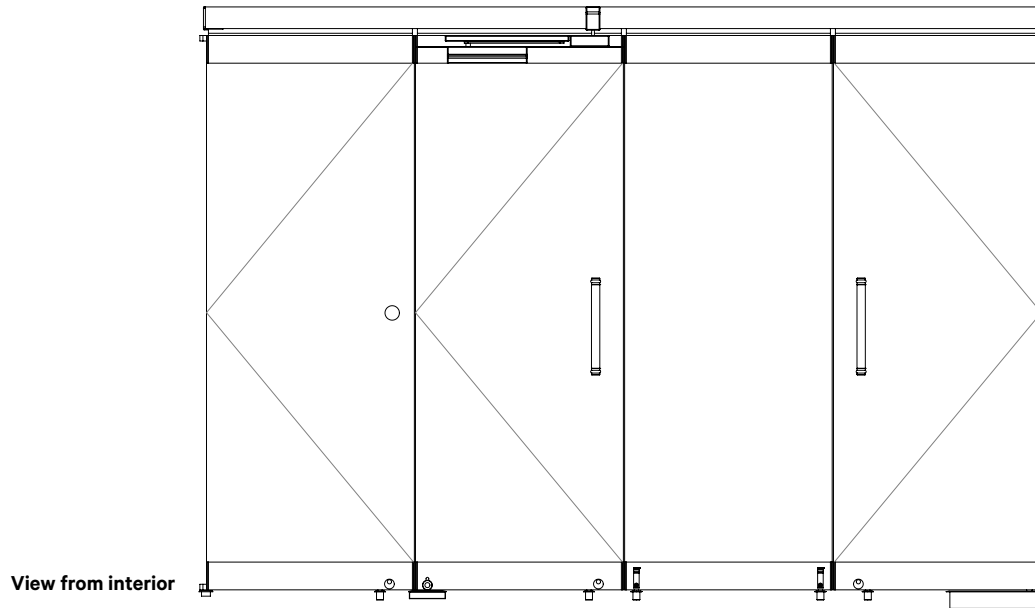

Maximum Panel Sizes with 1/2" (12 mm) Glass	Single Action End Panel (Non-sliding)	Single Action Sliding Panel	Sliding Panel	Single/Double Action End Panel (Non-sliding)
Maximum Unit Height	10' 6" (3200 mm)	10' 6" (3200 mm)	10' 6" (3200 mm)	10' 6" (3200 mm)
Maximum Panel Width	3' 7" (1100 mm)	3' 3" (1000 mm)	4' 1" (1250 mm)	3' 7" (1100 mm)

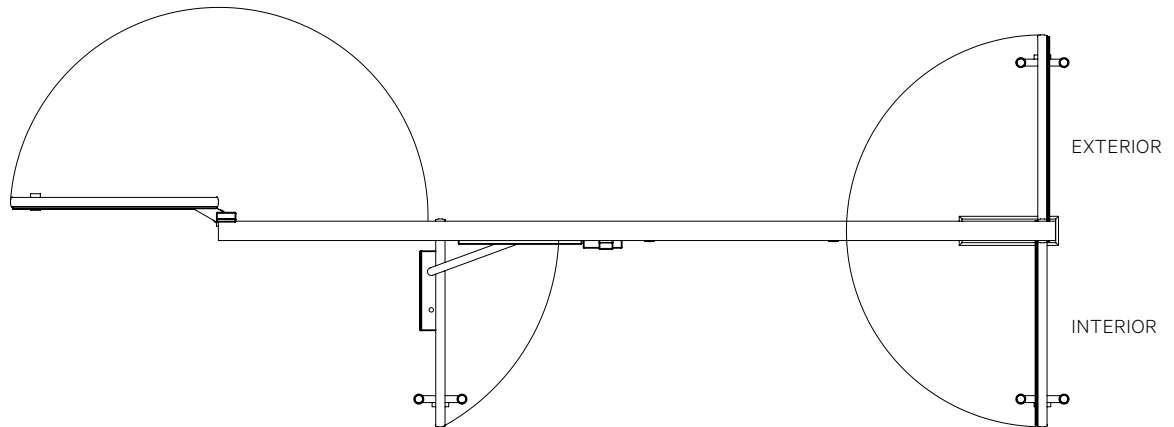

The individual panels can also be of differing widths.

**Please check with NanaWall for maximum sizes for other glass thickness.**

Maximum sizes for 1/2" (12 mm) as shown is per Glass Association of North America (GANA) recommendations, provided that the supplied H-Profiles are field installed between sliding panels. Please check applicable codes for maximum allowed height for the relevant glass thickness.

Applicable codes may limit the maximum sizes possible to be less than what NanaWall allows.

**Elevation Drawings and plan views of typical parking bay configurations.**

Please see referenced cross-section details. Should you require design assistance on the many parking bay possibilities, please consult <https://www.nanawall.com/professionals/design-assistance>. NanaWall Systems offers a complimentary 3D Conceptual Drawings service and 3D Configurator for CAD/Revit/Specs to help in the design/development process.

**Note:** The number of panels in a system is unlimited. Selective sliding panels can be converted into a single action panel with the option of single/double action end panels on either side of the configuration.

**PARKING BAY A**  
with Double Action End Panel

Perpendicular stacking in the opening with double action end panel and floor closer

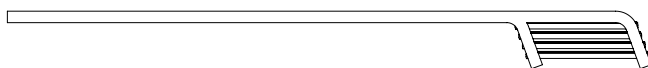
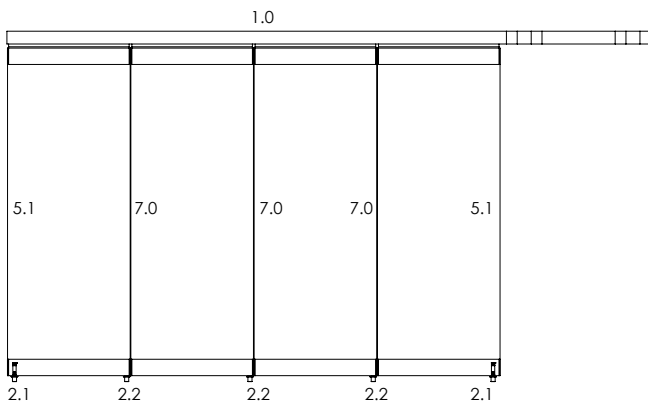
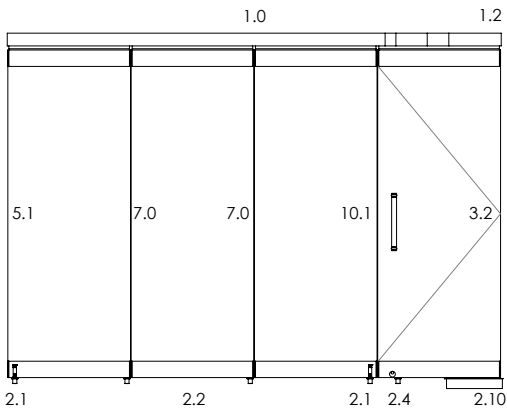

**PARKING BAY B**  
with Single Action Sliding Panel

Parallel stacking outside the opening with a single action sliding panel with top door closer and pivot box

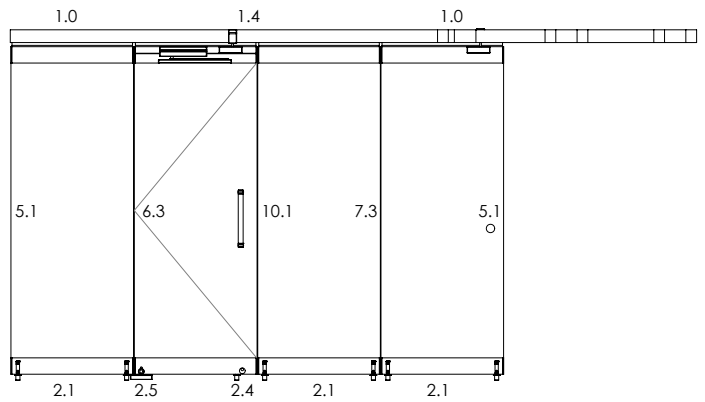

**PARKING BAY C**  
with Sliding Panels

Parallel stacking outside the opening



**Elevation Drawings and plan views of typical parking bay configurations.**

Please see referenced cross-section details. Should you require design assistance on the many parking bay possibilities, please consult <https://www.nanawall.com/professionals/design-assistance>. NanaWall Systems offers a complimentary 3D Conceptual Drawings service and 3D Configurator for CAD/Revit/Specs to help in the design/development process.

**Note:** The number of panels in a system is unlimited. Selective sliding panels can be converted into a single action panel with the option of single/double action end panels on either side of the configuration.

**PARKING BAY E**  
with Single Action Sliding Panel and Non-Entry Single Action End Panel at Other End

Parallel stacking outside the opening with single action sliding panel with top door closer and pivot box at the left and non-entry single action end panel with offset hinge at the right

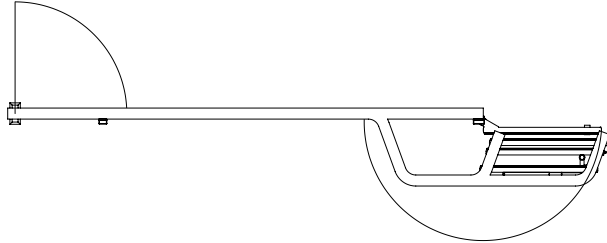
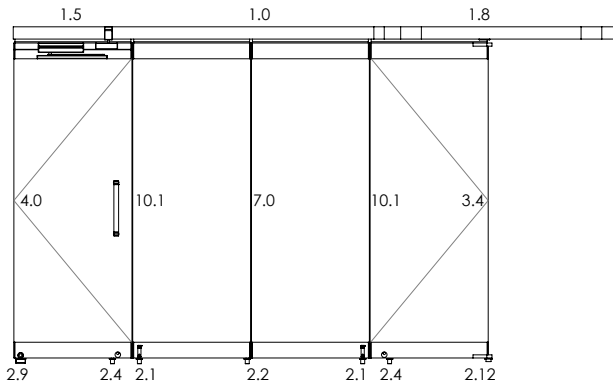

**PARKING BAY G**  
with Single Action Sliding Panel and Non-Entry Single Action End Panel at Other End

Parallel stacking outside the opening with single action sliding panel with top door closer and pivot box at the left and non-entry single action end panel with offset hinge at the right

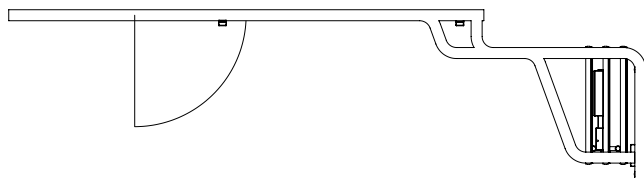
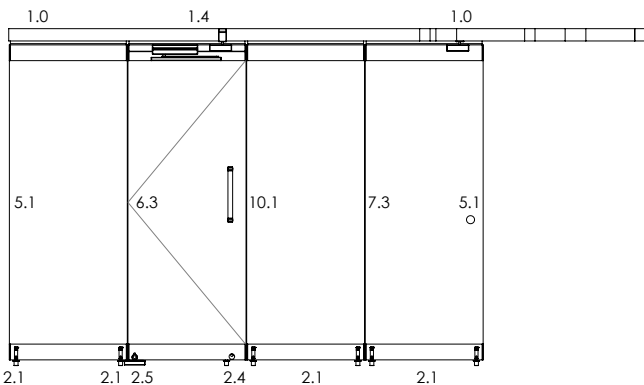
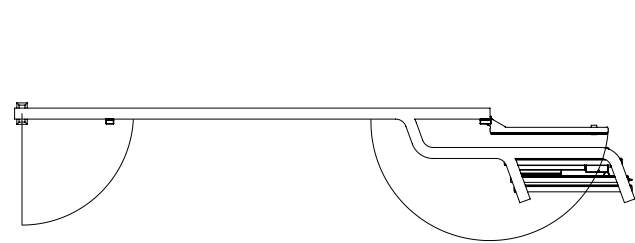
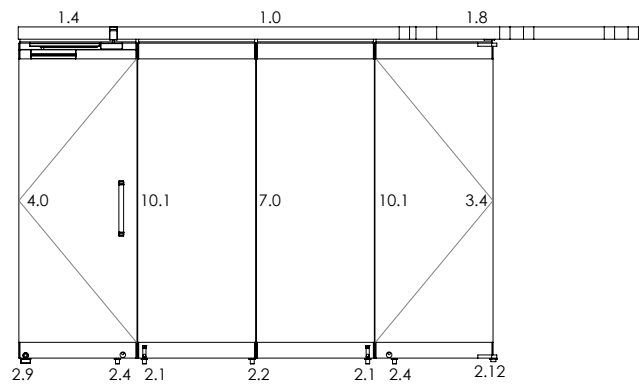

**PARKING BAY H**  
with Single Action Sliding Panel

Perpendicular stacking outside the opening with single action sliding panel with top door closer and pivot box with additional top track locking

**Elevation Drawings and plan views of typical parking bay configurations.**

Please see referenced cross-section details. Should you require design assistance on the many parking bay possibilities, please consult <https://www.nanawall.com/professionals/design-assistance>. NanaWall Systems offers a complimentary 3D Conceptual Drawings service and 3D Configurator for CAD/Revit/Specs to help in the design/development process.

**Note:** The number of panels in a system is unlimited. Selective sliding panels can be converted into a single action panel with the option of single/double action end panels on either side of the configuration.

**PARKING BAY I**  
with Single Action Sliding Panel and Non-Entry Single Action End Panel

Perpendicular stacking outside the opening with single action sliding panel with top door closer and pivot box and non-entry single action end panel hinged to the sliding panel on the right

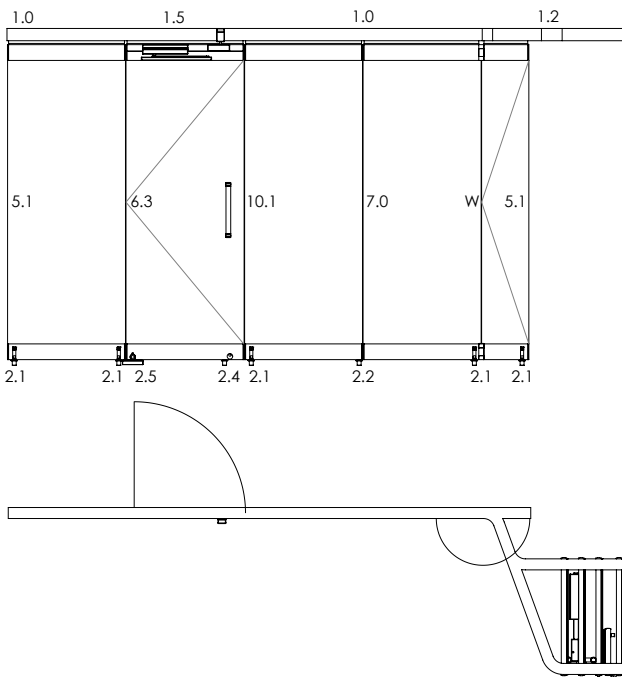

**PARKING BAY M**  
with Single Action Sliding Panel and Non-Entry Single Action End Panel at Other End

Parallel stacking outside the opening with single action sliding panel with top door closer and pivot box on the left and non-entry single action end panel with offset hinge on the right

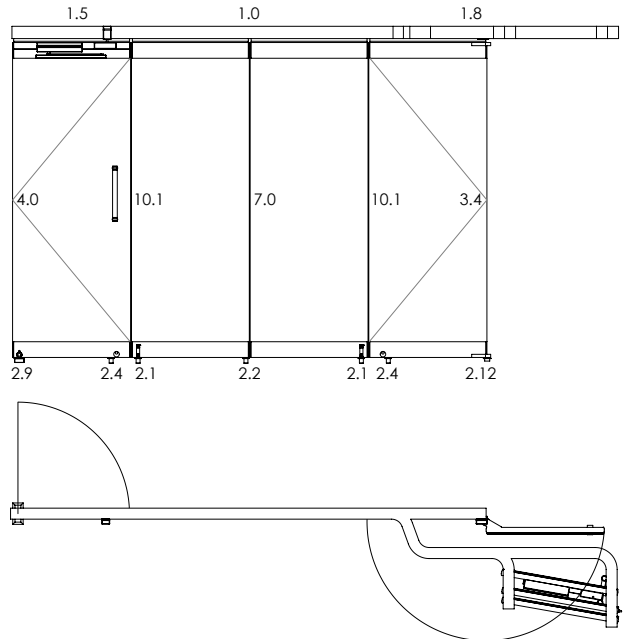

**PARKING BAY N**  
with Single Action Sliding Panel

Parallel stacking outside the opening with single action sliding panel with top door closer and pivot box with additional top track locking

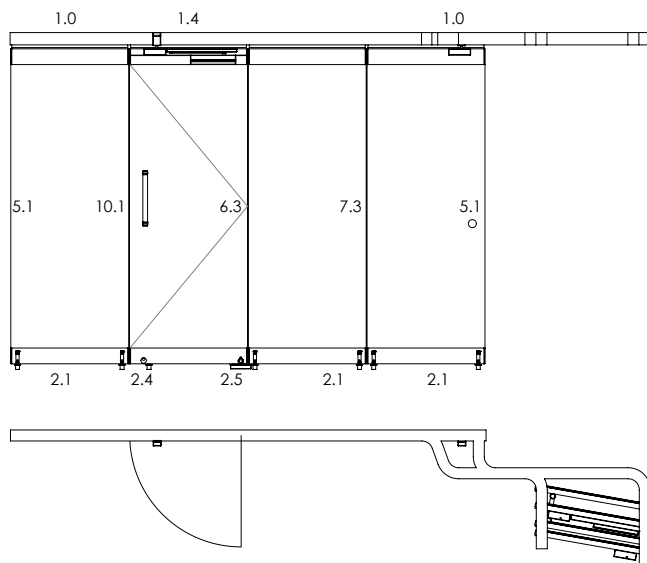

**Elevation Drawings and plan views of typical parking bay configurations.**

Please see referenced cross-section details. Should you require design assistance on the many parking bay possibilities, please consult <https://www.nanawall.com/professionals/design-assistance>. NanaWall Systems offers a complimentary 3D Conceptual Drawings service and 3D Configurator for CAD/Revit/Specs to help in the design/development process.

**Note:** The number of panels in a system is unlimited. Selective sliding panels can be converted into a single action panel with the option of single/double action end panels on either side of the configuration.

**PARKING BAY P**  
**with Single Action Sliding Panel and Non-Entry Single Action End Panel at Other End**

Parallel stacking outside the opening with single action sliding panel with top door closer and pivot box on the left and non-entry single action end panel with offset hinge on the right

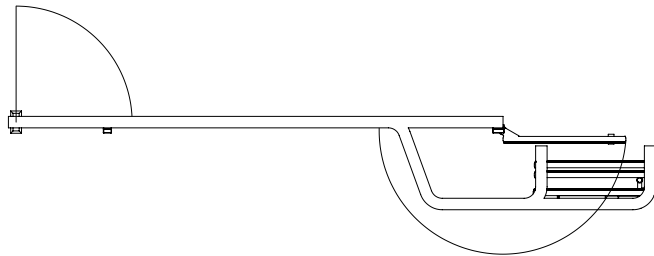
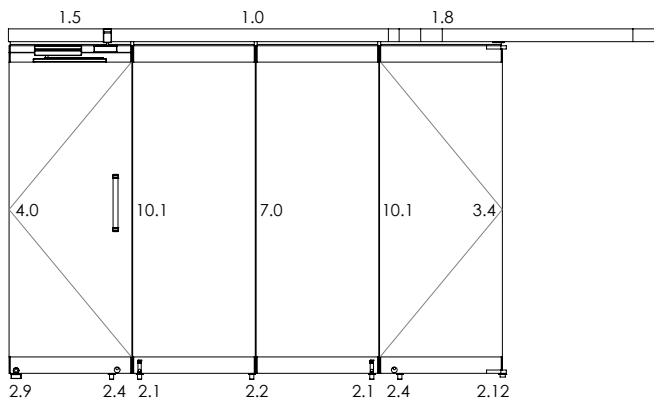

**Elevation Drawings and plan views of typical parking bay configurations.**

Please see referenced cross-section details. Should you require design assistance on the many parking bay possibilities, please consult <https://www.nanawall.com/professionals/design-assistance>. NanaWall Systems offers a complimentary 3D Conceptual Drawings service and 3D Configurator for CAD/Revit/Specs to help in the design/development process.

**Note:** The number of panels in a system is unlimited. Selective sliding panels can be converted into a single action panel with the option of single/double action end panels on either side of the configuration.

**PARKING BAY J**

**Curved Configuration with Single Action End Panel**

Parallel stacking within the opening with single action end panel with floor closer

**Note:** Continuous curved head track possible with gentle curve only - otherwise a segmented head track will be provided.

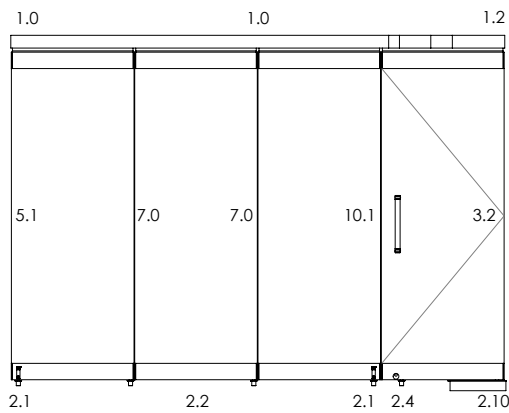

**Elevation Drawings and plan views of typical parking bay configurations.**

Please see referenced cross-section details. Should you require design assistance on the many parking bay possibilities, please consult <https://www.nanawall.com/professionals/design-assistance>. NanaWall Systems offers a complimentary 3D Conceptual Drawings service and 3D Configurator for CAD/Revit/Specs to help in the design/development process.

**Note:** The number of panels in a system is unlimited. Selective sliding panels can be converted into a single action panel with the option of single/double action end panels on either side of the configuration.

**PARKING BAY G**

**90° Open Corner Configuration with Single Action End Panel**

Parallel stacking outside the opening with single action end panel with floor closer and offset hinge

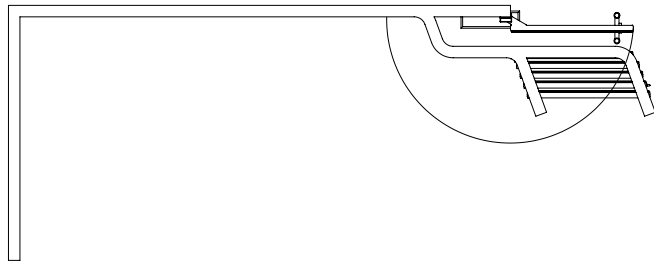
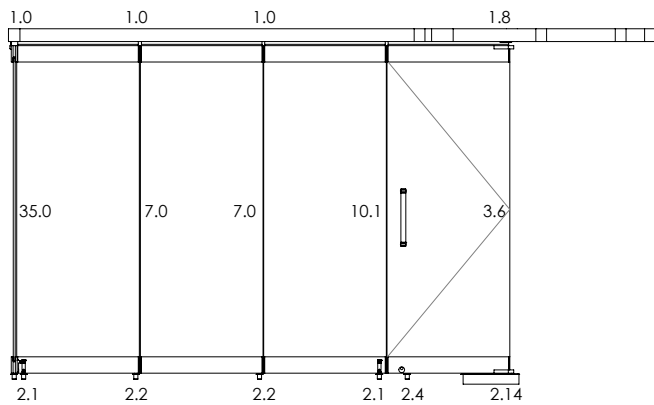

**Elevation Drawings and plan views of typical parking bay configurations.**

Please see referenced cross-section details. Should you require design assistance on the many parking bay possibilities, please consult <https://www.nanawall.com/professionals/design-assistance>. NanaWall Systems offers a complimentary 3D Conceptual Drawings service and 3D Configurator for CAD/Revit/Specs to help in the design/development process.

**Note:** The number of panels in a system is unlimited. Selective sliding panels can be converted into a single action panel with the option of single/double action end panels on either side of the configuration.

**PARKING BAY A, G, & J**

**T-Intersection Configuration with Single Action End Panels**

Various parallel and perpendicular stacking with single action end panels with offset hinge and floor closer

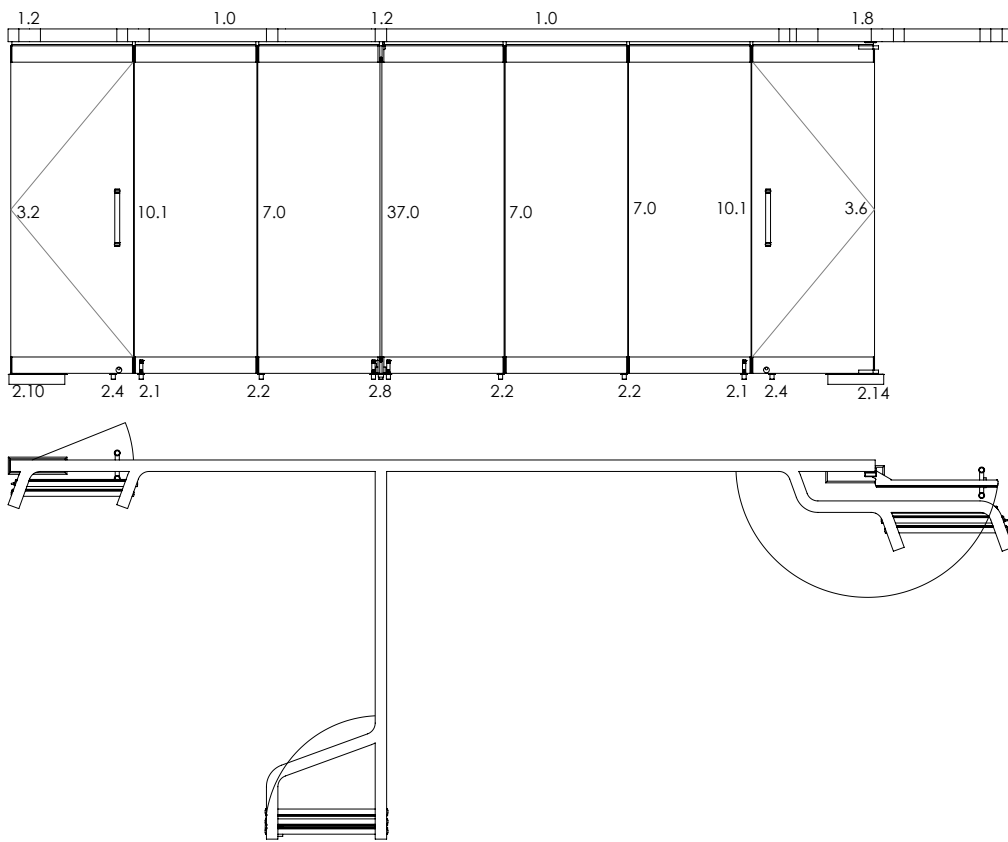

**Elevation Drawings and plan views of typical parking bay configurations.**

Please see referenced cross-section details. Should you require design assistance on the many parking bay possibilities, please consult <https://www.nanawall.com/professionals/design-assistance>. NanaWall Systems offers a complimentary 3D Conceptual Drawings service and 3D Configurator for CAD/Revit/Specs to help in the design/development process.

**Note:** The number of panels in a system is unlimited. Selective sliding panels can be converted into a single action panel with the option of single/double action end panels on either side of the configuration.

**PARKING BAY A**

**4-Way Stop Configuration with Single Action End Panels**

Perpendicular stacking in the opening with single action end panels with floor closer

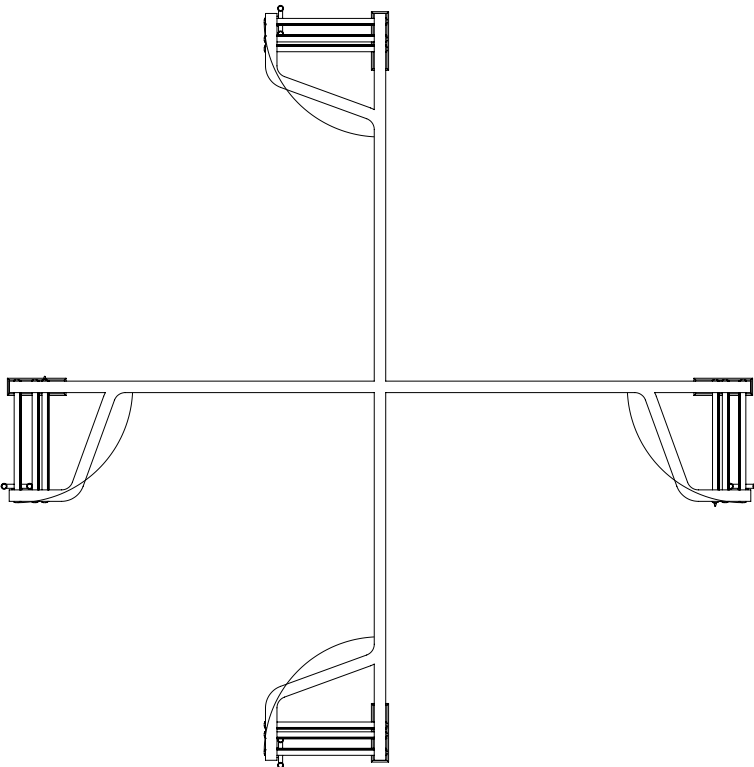
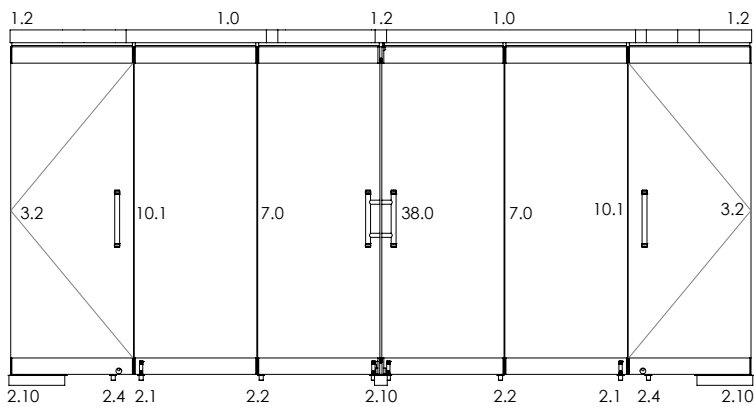

**Elevation Drawings and plan views of typical parking bay configurations.**

Please see referenced cross-section details. Should you require design assistance on the many parking bay possibilities, please consult <https://www.nanawall.com/professionals/design-assistance>. NanaWall Systems offers a complimentary 3D Conceptual Drawings service and 3D Configurator for CAD/Revit/Specs to help in the design/development process.

**Note:** The number of panels in a system is unlimited. Selective sliding panels can be converted into a single action panel with the option of single/double action end panels on either side of the configuration.

**PARKING BAY A**

**Window Door Combination Configuration with Single Action Sliding Panel**

Perpendicular stacking in the opening with single action sliding panel with top door closer and pivot box

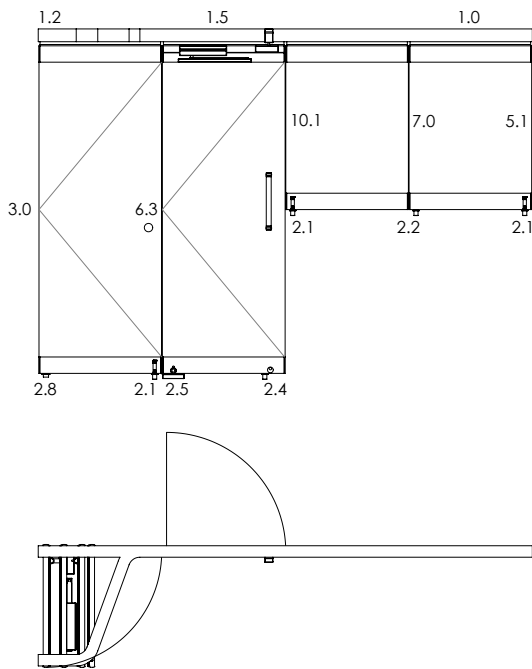



Details are shown with 1/2" (12 mm) thick glass. For different glass thicknesses and rail heights, please contact NanaWall.

**Detail 1.0**  
Head Profile - Sliding Panel

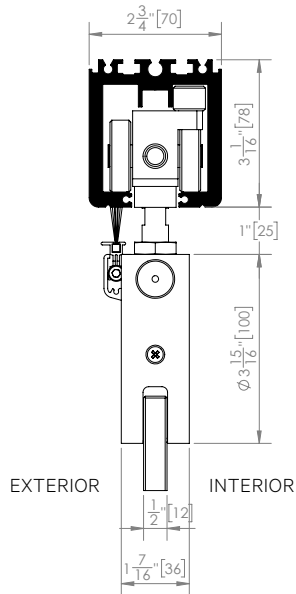

**Detail 2.1**  
Bottom Profile - Sliding Panel with Foot Activated Floor Bolt

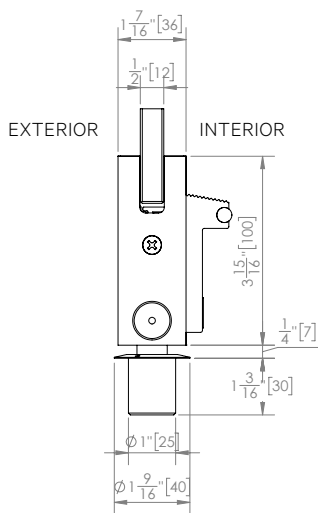

**Detail 2.2**  
Bottom Profile - Sliding Panel with Concealed Interlock

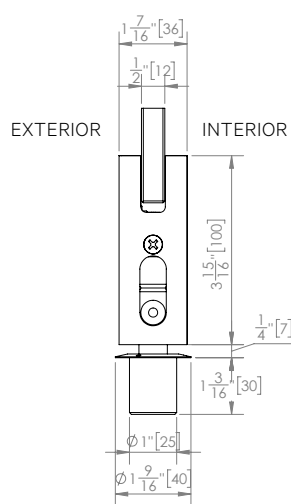

**Detail 2.0**  
Bottom Profile - Sliding Panel with Quick Release Floor Bolt

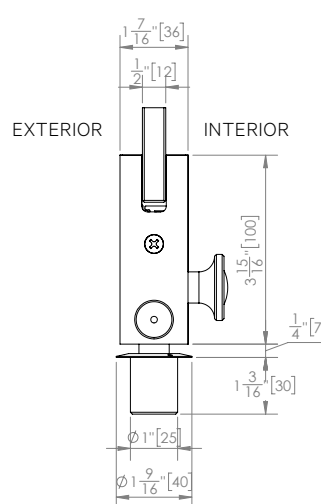

**Detail 2.3**  
Bottom Profile - Sliding Panel with Concealed Automatic Interlock

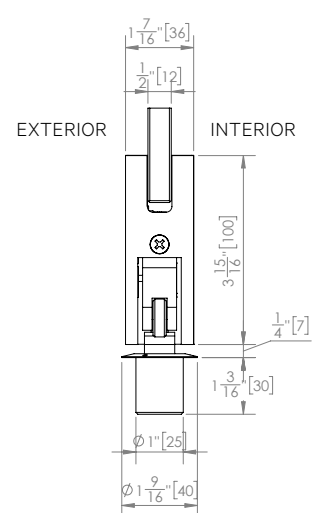

**Note:** Standard to all sliding panels, recessed polyamide bumpers are added to the end caps at the top and bottom of one side of the panel to reduce metal-to-metal or glass-to-glass contact.

Details are shown with 1/2" (12 mm) thick glass. For different glass thicknesses and rail heights, please contact NanaWall.

**Detail 1.8**

Head Profile - Single Action End Panel with Offset Hinge (Inswing)

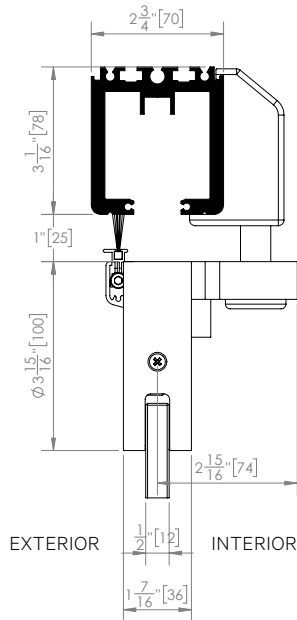

**Detail 1.9**

Head Profile - Single Action End Panel with Offset Hinge (Outswing)

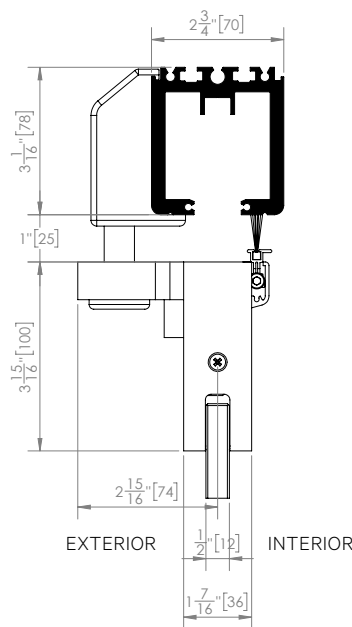

**Detail 2.14**

Bottom Profile - Single Action End Panel with Offset Hinge and Floor Closer (Inswing)

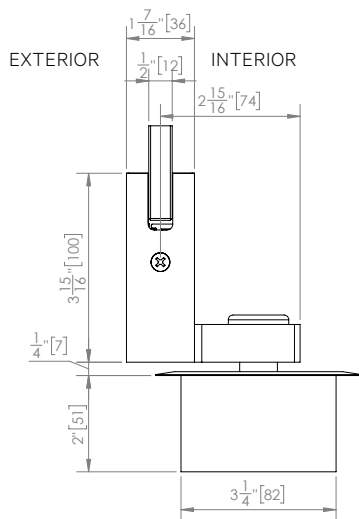

**Detail 2.15**

Bottom Profile - Single Action End Panel with Offset Hinge and Floor Closer (Outswing)

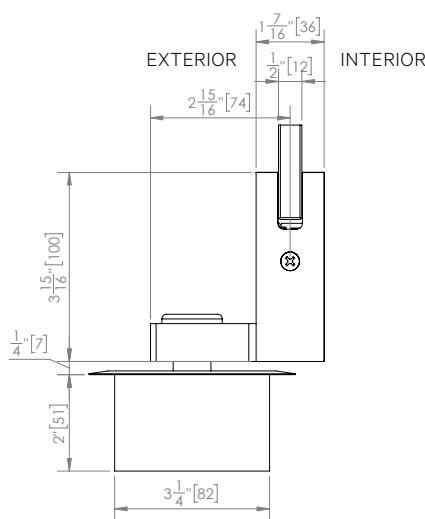

**Detail 2.4**

Bottom Profile with Mortise Key/Key Cylinder

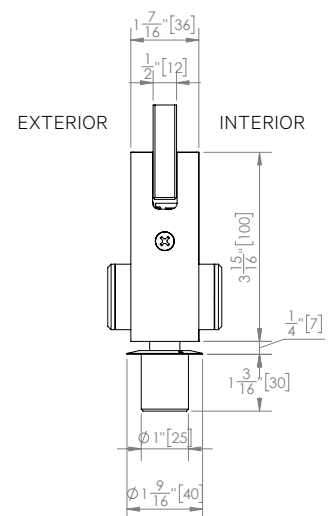

Details are shown with 1/2" (12 mm) thick glass. For different glass thicknesses and rail heights, please contact NanaWall.

**Detail 1.10**

Head Profile - Single Action End Panel with Offset Hinge and Top Door Closer (Inswing)

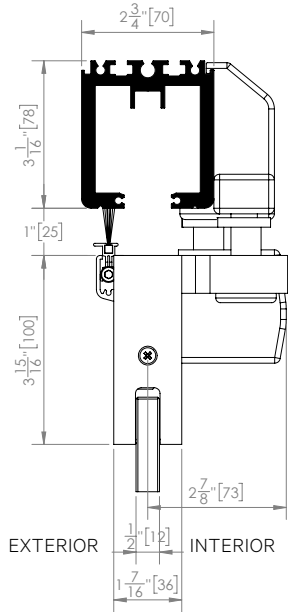

**Detail 1.11**

Head Profile - Single Action End Panel with Offset Hinge and Top Door Closer (Outswing)

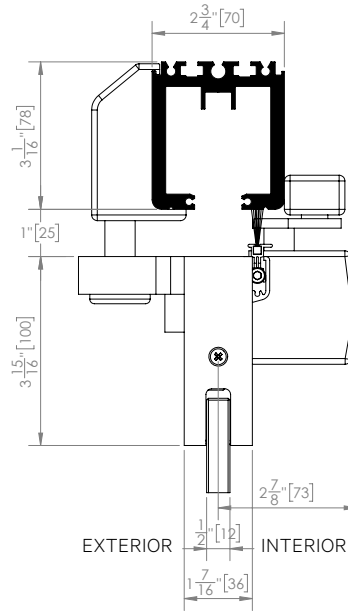

**Detail 2.12**

Bottom Profile - Single Action End Panel with Offset Hinge and Pivot Point (Inswing)

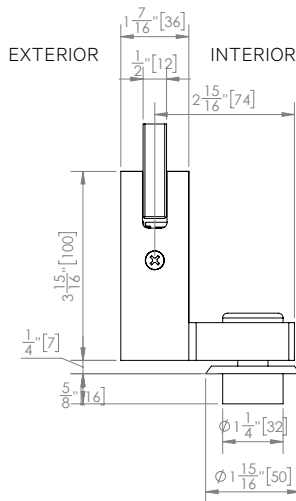

**Detail 2.11**

Bottom Profile - Single Action End Panel with Offset Hinge and Pivot Point (Outswing)

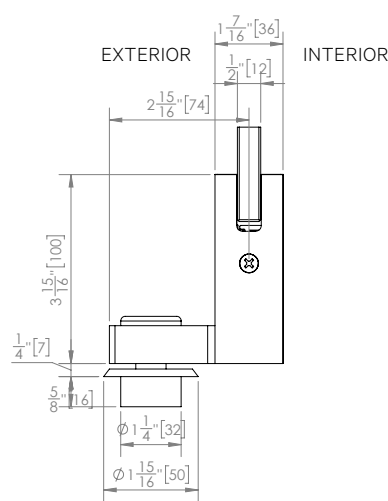

Details are shown with 1/2" (12 mm) thick glass. For different glass thicknesses and rail heights, please contact NanaWall.

**Detail 1.2**

Head Profile - Single/Double Action  
End Panel with Pivot Point

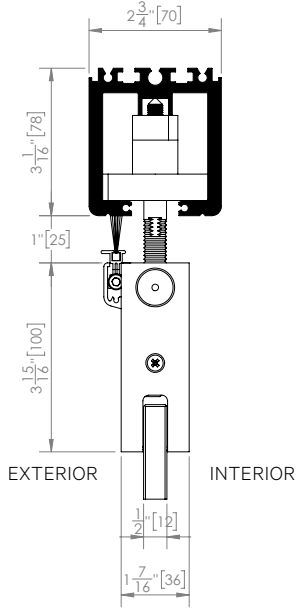

**Detail 2.8**

Bottom Profile - Single/Double Action  
End Panel with Pivot Point

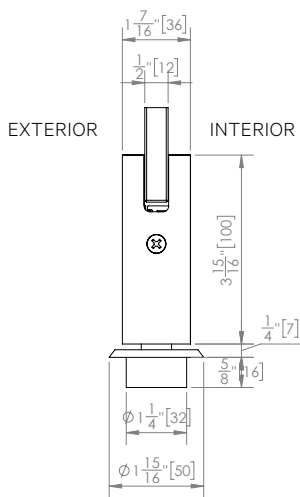

**Detail 2.10**

Bottom Profile - Single/Double Action  
End Panel with Floor Closer

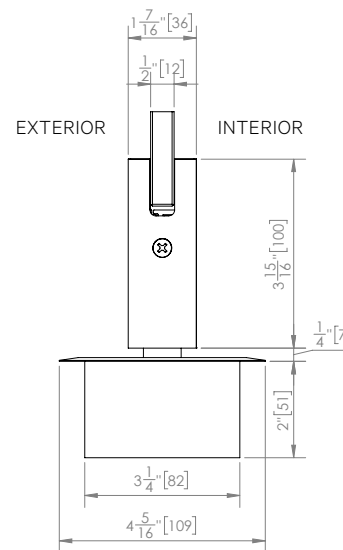

Details are shown with 1/2" (12 mm) thick glass. For different glass thicknesses and rail heights, please contact NanaWall.

**Detail 1.4**

Head Profile - Single Action Sliding Panel with Top Door Closer (Inswing)

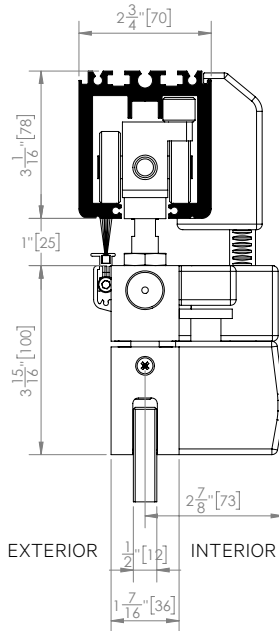

**Detail 1.5**

Head Profile - Single Action Sliding Panel with Top Door Closer (Outswing)

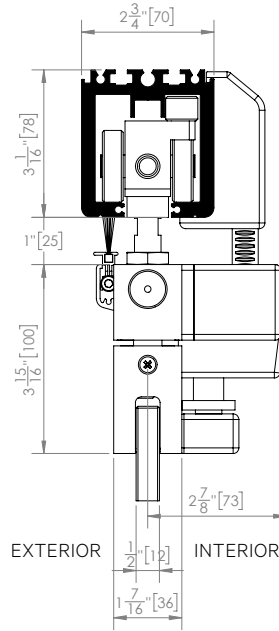

**Detail 2.5**

Bottom Profile - Single Action Sliding Panel with Pivot Box Parallel to the Panel (Inswing and Outswing)

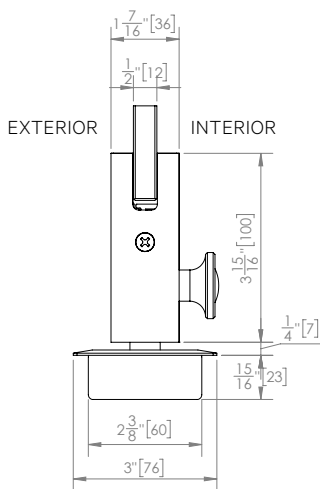

**Detail 2.9**

Bottom Profile - Single Action Sliding Panel with Pivot Box Perpendicular to the Panel (Inswing and Outswing)

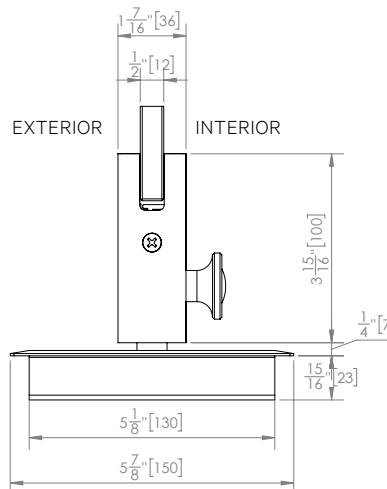

**Note:** Standard to all sliding panels, recessed polyamide bumpers are added to the end caps at the top and bottom of one side of the panel to reduce metal-to-metal or glass-to-glass contact.

Details are shown with 1/2" (12 mm) thick glass. For different glass thicknesses and rail heights, please contact NanaWall.

**Typical Kickplate Height**

Maximum kickplate height available is 10" (254 mm).

For other options, contact NanaWall.

**Aluminum Chamfer Rail**

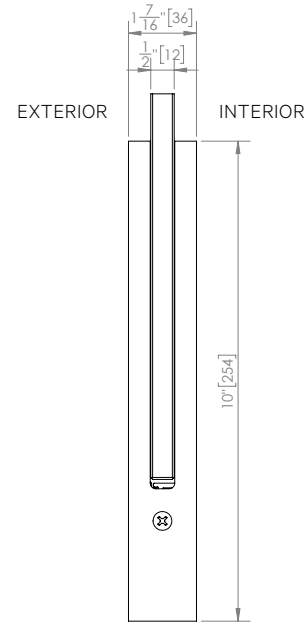
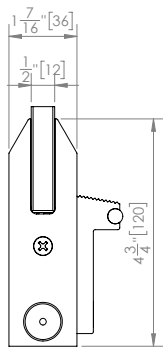

Details are shown with 1/2" (12 mm) thick glass. For different glass thicknesses and rail heights, please contact NanaWall.

**Detail 7.0**

Meeting of Sliding Panels with  
Concealed Interlock

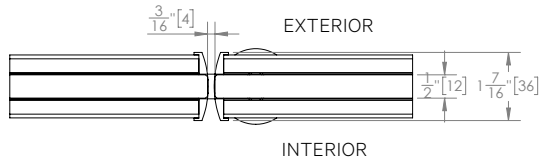

**Detail 7.1**

Meeting of Sliding Panels with  
Concealed Automatic Interlock

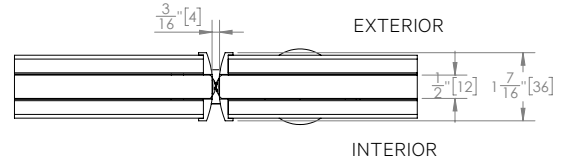

**Detail 7.3**

Meeting of Sliding Panels with  
Foot Activated Floor Bolts

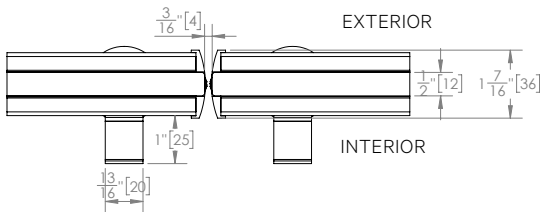

**Detail W**

Non-Entry Single Action End Panel  
Hinged to the Sliding Panel

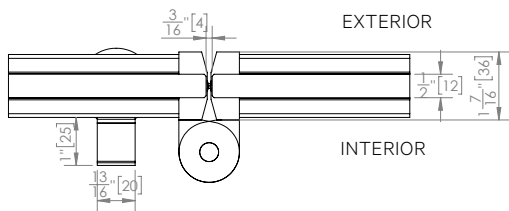

**Note:** Standard to all sliding panels, recessed polyamide bumpers are added to the end caps at the top and bottom of one side of the panel to reduce metal-to-metal or glass-to-glass contact.

Details are shown with 1/2" (12 mm) thick glass. For different glass thicknesses and rail heights, please contact NanaWall.

**Detail 6.3**

Meeting of Sliding Panel and Single Action Sliding Panel with Foot Activated Floor Bolt and Pivot Box on the Pivot End of the Panel

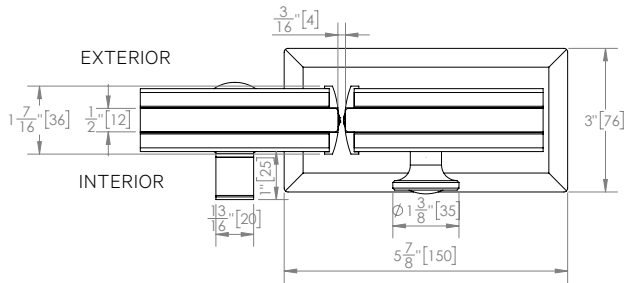

**Detail 6.4**

Meeting of Sliding Panel and Single Action Sliding Panel with Foot Activated Floor Bolt and Pivot Box on the Pivot End of the Panel

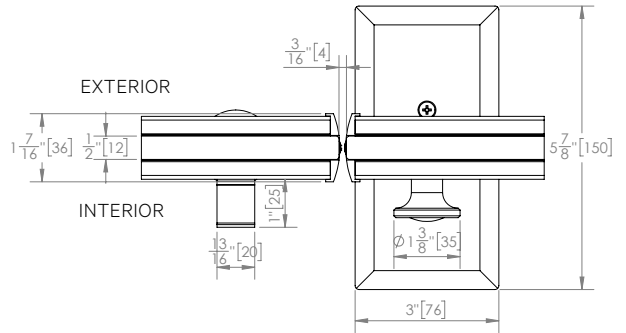

**Detail 10.1**

Meeting of Sliding Panel and Single/Double Action End Panel or Single Action Sliding Panel with Foot Activated Floor Bolt and Mortise Key/Key Cylinder on the Swing End of the Panel

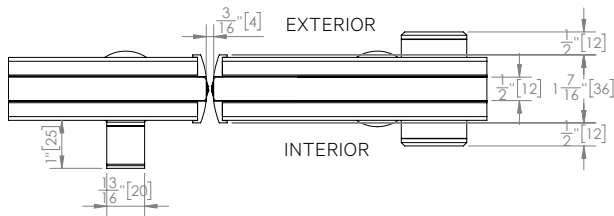

**Detail 6.1**

Meeting of Sliding Panel and Single/Double Action End Panel with Foot Activated Floor Bolts on the Swing End of the Panel

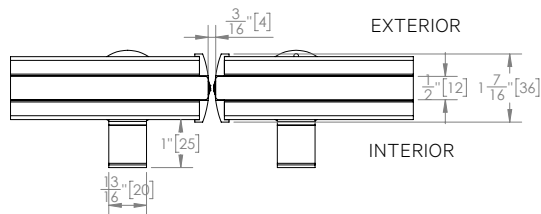

**Note:** Standard to all sliding panels, recessed polyamide bumpers are added to the end caps at the top and bottom of one side of the panel to reduce metal-to-metal or glass-to-glass contact.



Details are shown with 1/2" (12 mm) thick glass. For different glass thicknesses and rail heights, please contact NanaWall.

**Detail 8.0**

Meeting of Single/Double Action End Panels or Single Action Sliding Panels with Mortise Key/Key Cylinders on the Swing End of the Panel

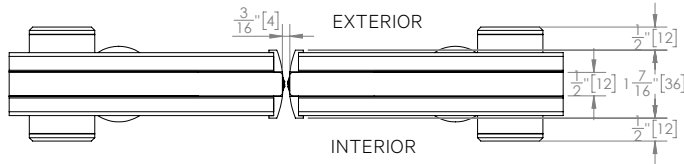

**Detail 5.1**

End Sliding Panel with Foot Activated Floor Bolt

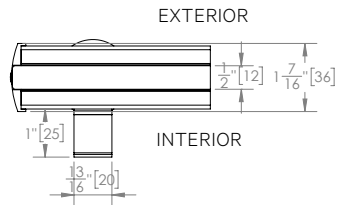

**Detail 5.2**

End Sliding Panel with Mortise Key/Key Cylinder

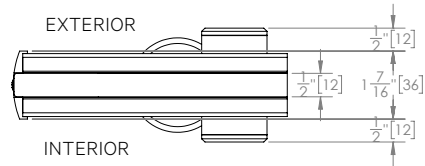

Details are shown with 1/2" (12 mm) thick glass. For different glass thicknesses and rail heights, please contact NanaWall.

**Detail 3.0**

Single/Double Action End Panel with Pivot Point

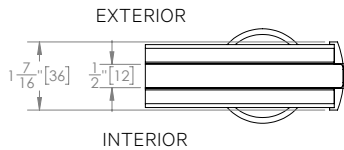

**Detail 4.0**

Single Action Sliding Panel with Pivot Box and Quick Release Floor Bolt Perpendicular to the Panel

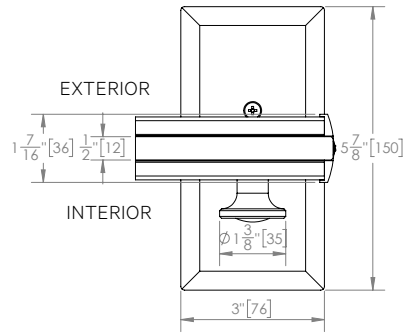

**Detail 3.4**

Single Action End Panel with Offset Hinge (Inswing)

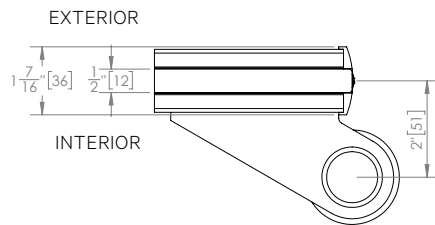

**Detail 3.3**

Single Action End Panel with Offset Hinge (Outswing)

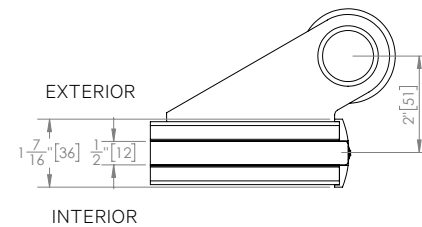

Details are shown with 1/2" (12 mm) thick glass. For different glass thicknesses and rail heights, please contact NanaWall.

**Detail 3.2**

Single/Double Action End Panel with Floor Closer (Inswing and Outswing)

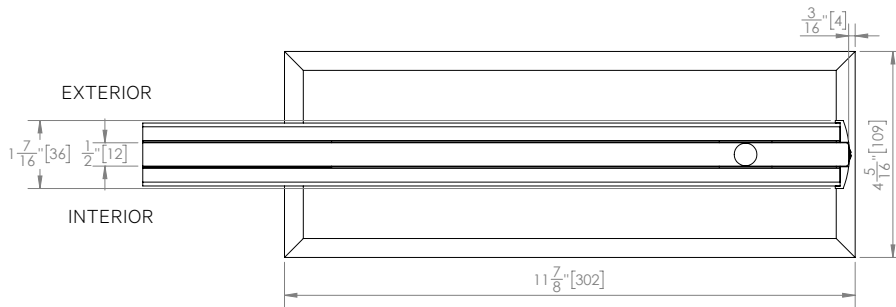

**Detail 3.6**

Single Action End Panel with Offset Hinge and Floor Closer (Inswing)

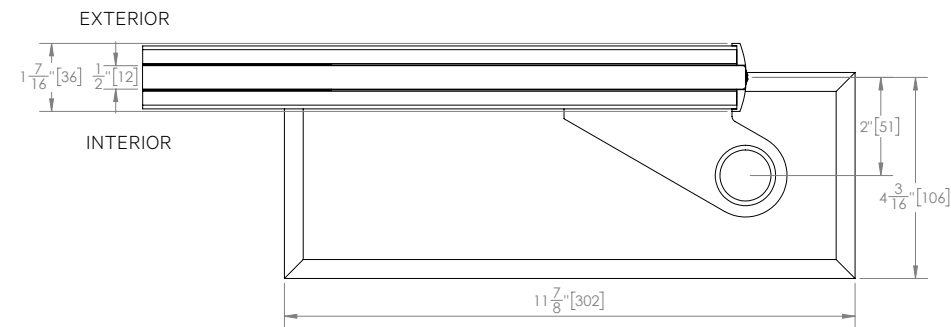

**Detail 3.7**

Single Action End Panel with Offset Hinge and Floor Closer (Outswing)

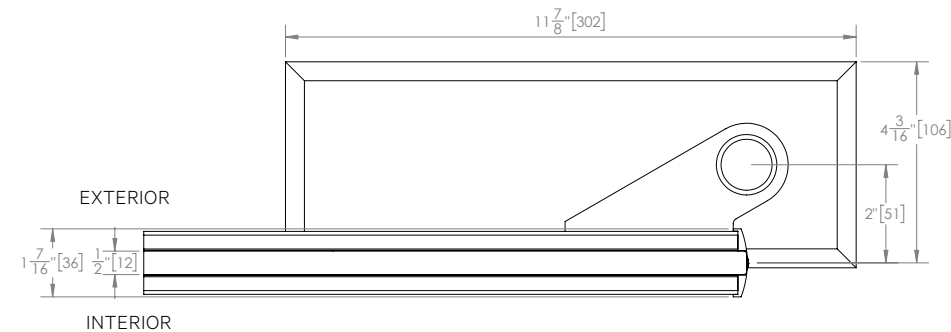

Details are shown with 1/2" (12 mm) thick glass. For different glass thicknesses and rail heights, please contact NanaWall.

**Detail 35**

90° Open Corner; 2 Sliding Panels Meet at Corner Post with Foot Activated Floor Bolts

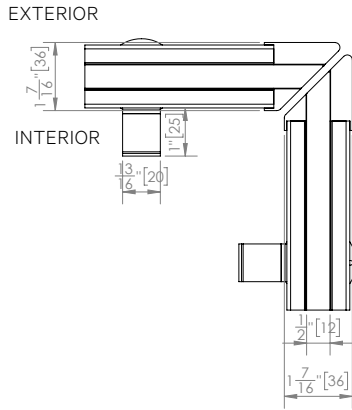

**Detail 36**

Segmented Corner; 2 Sliding Panels Meet at Corner Post with Foot Activated Floor Bolts

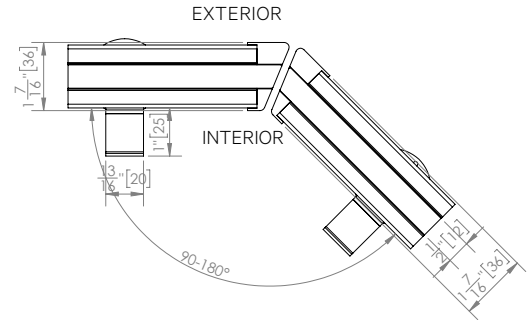

**Detail 37**

T-intersection; 3 Sliding Panels Meet at Corner Post with Foot Activated Floor Bolts

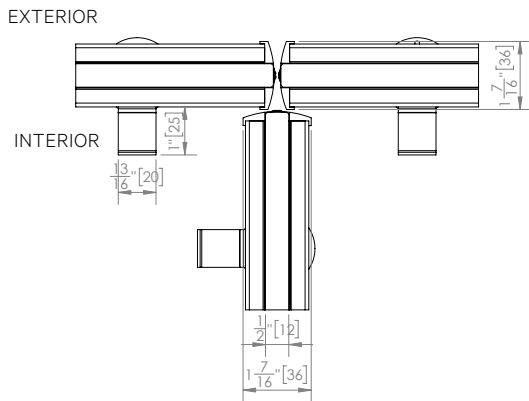

**Detail 38**

4-Way Stop; 4 Sliding Panels Meet at Corner Post with Foot Activated Floor Bolts

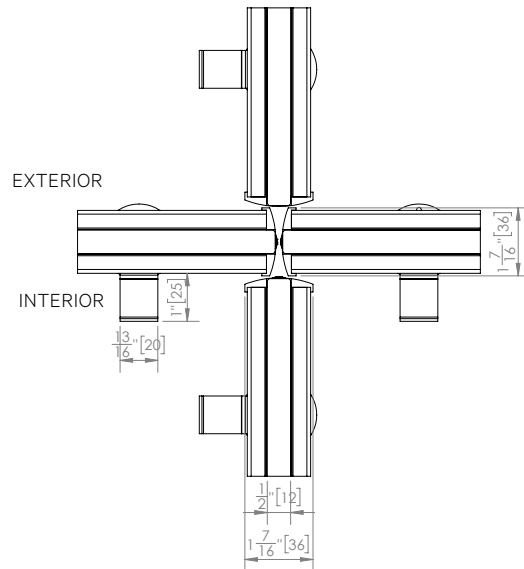

Details are shown with 1/2" (12 mm) thick glass. For different glass thicknesses and rail heights, please contact NanaWall.

Head Track with L-Bracket

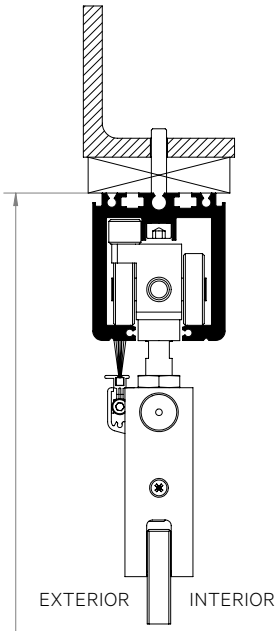

Head Track with Steel Tube

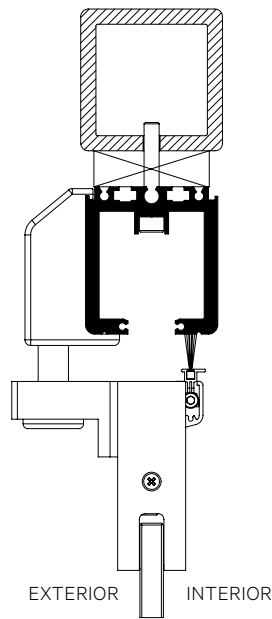

Head Track and Suspended Ceiling Support Profile with I-Beam

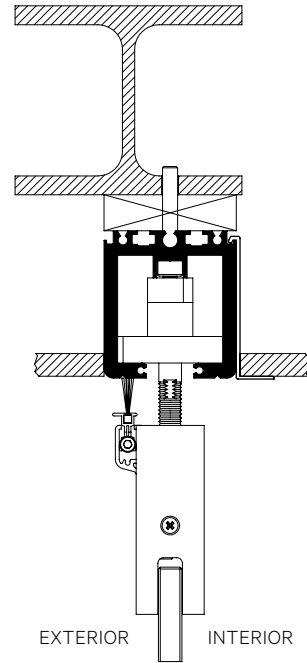

UNIT HEIGHT

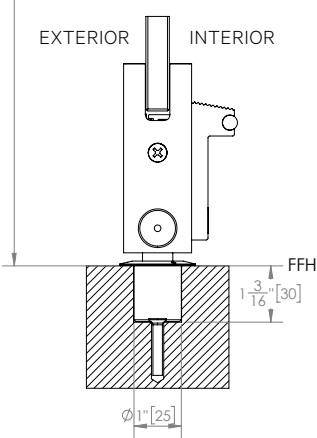

Adjustable Eccentric Floor Socket

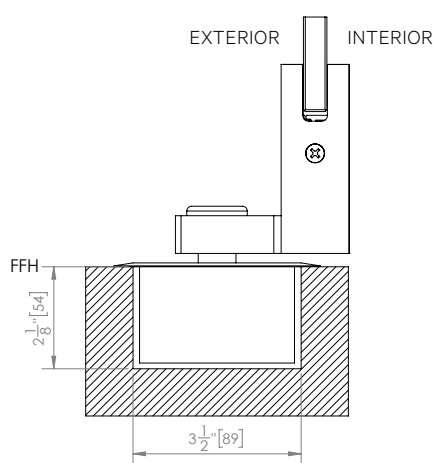

Offset Hinge and Floor Closer for Single Action End Panel

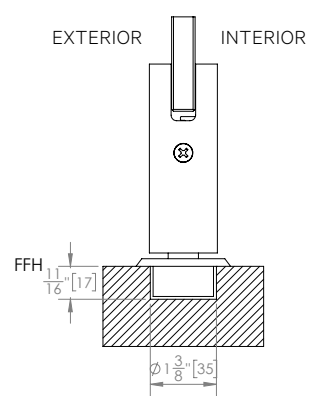

Pivot Point for Single/Double Action End Panel

Details are shown with 1/2" (12 mm) thick glass. For different glass thicknesses and rail heights, please contact NanaWall.

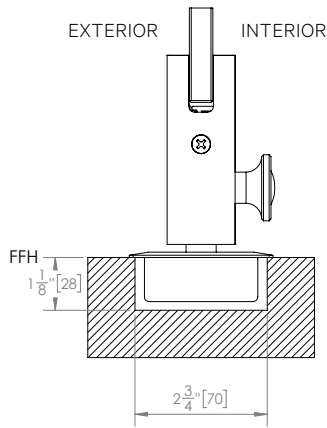

Pivot Box for the Single Action Sliding Panel Parallel to the Panel

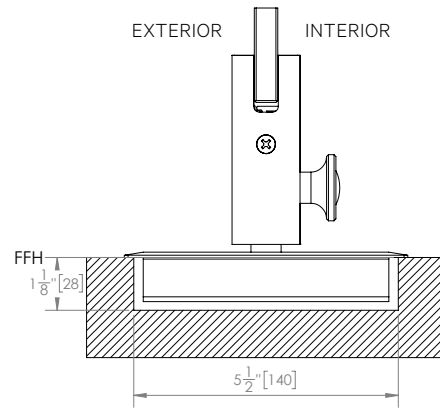

Pivot Box for Single Action Sliding Panel Perpendicular to the Panel



Adjustable Floor Socket with Eccentric Insert



Floor Socket for Concealed Automatic Interlock with Black Polyamide Insert

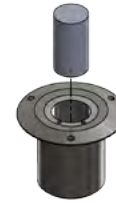

Floor Socket with High Heel Protector Insert



Bottom Profile with Foot Activated Floor Bolt



Bottom Profile with Concealed Interlock



Bottom Profile with Quick Release Floor Bolt with Spring Loaded Security Feature

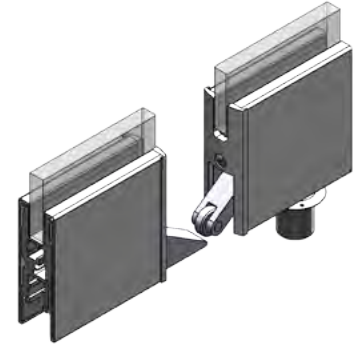

Bottom Profile with Concealed Automatic Interlock

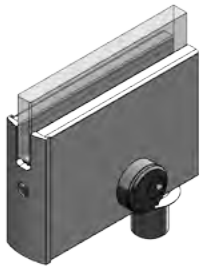

Bottom Profile with Mortise Key/Key Cylinder



Bottom Profile of Single/Double Action End Panel with Pivot Point

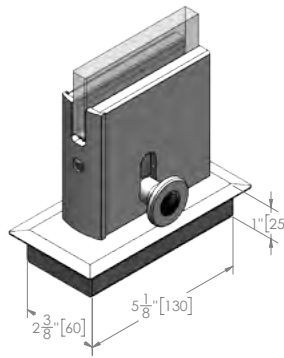

Bottom Profile of Single Action Sliding Panel with Pivot Box Parallel to the Panel

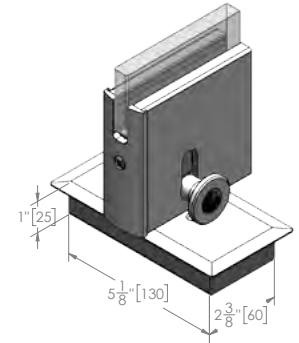

Bottom Profile of Single Action Sliding Panel with Pivot Box Perpendicular to the Panel



Bottom Profile of Single Action End Panel with Offset Hinge

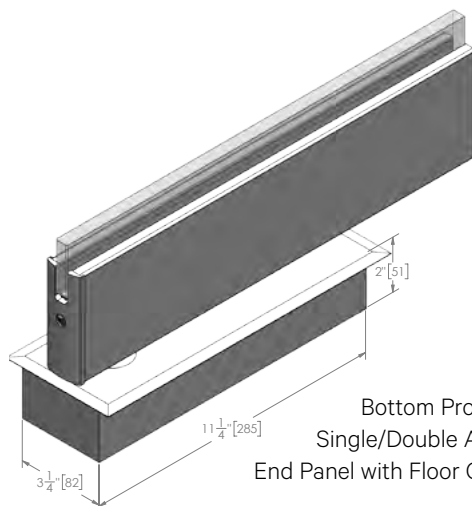

Bottom Profile of Single/Double Action End Panel with Floor Closer

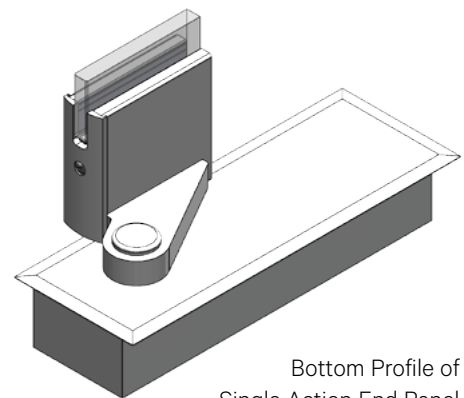

Bottom Profile of Single Action End Panel with Offset Hinge and Floor Closer



Aluminum Chamfer Rail



Bottom Profile for 45°  
Configuration

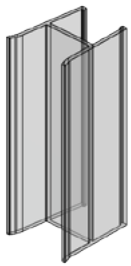

For **Detail 7.0,**  
**7.1, and 7.3**

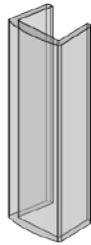

For **Detail 6.1, 6.3, 6.4,**  
**8.0, and 10.1**

Transparent H-Profile and Edge Protector Seal



