

Suggested Typical Installation Inward Opening Details NW Aluminum 640 and NW Reinforced 647

alternative options

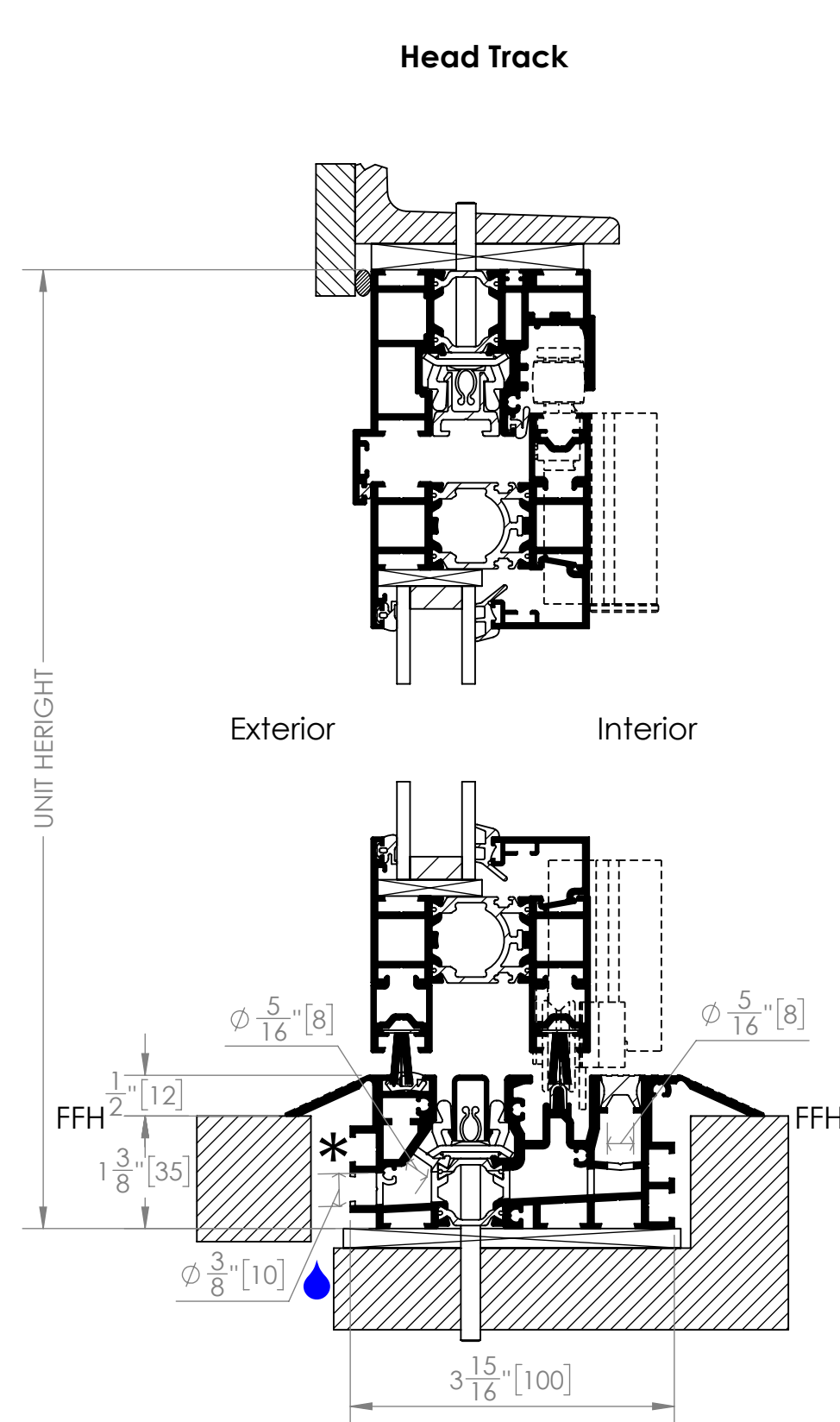

Low Profile Saddle Sill - Option 1
For any water rating, weep holes drilled in the sill and drain connections by others necessary. Please see Low Profile Saddle Sill Option 1 Detail Drawing on the right side for weep hole sizes, pattern and spacing by others

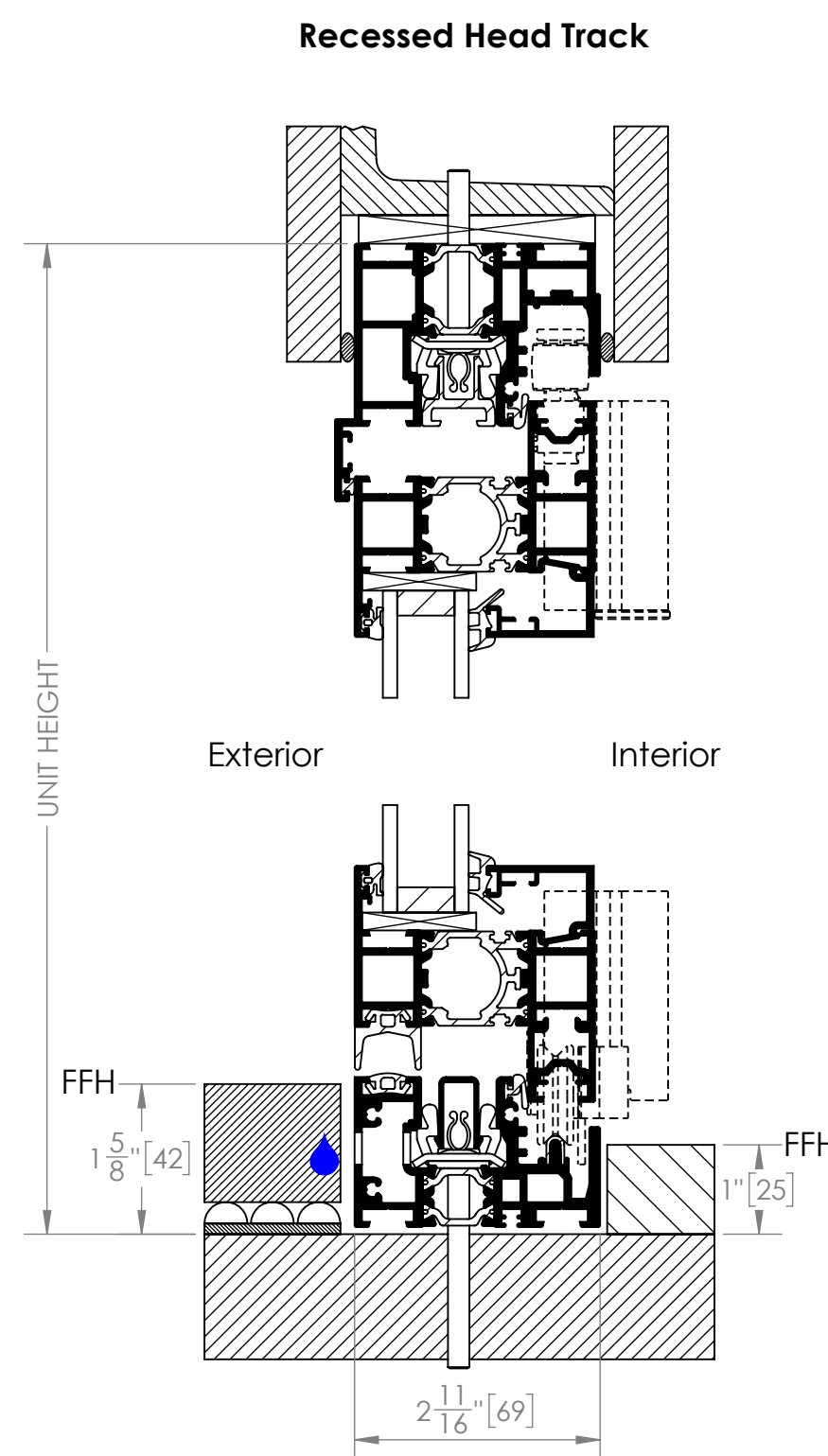
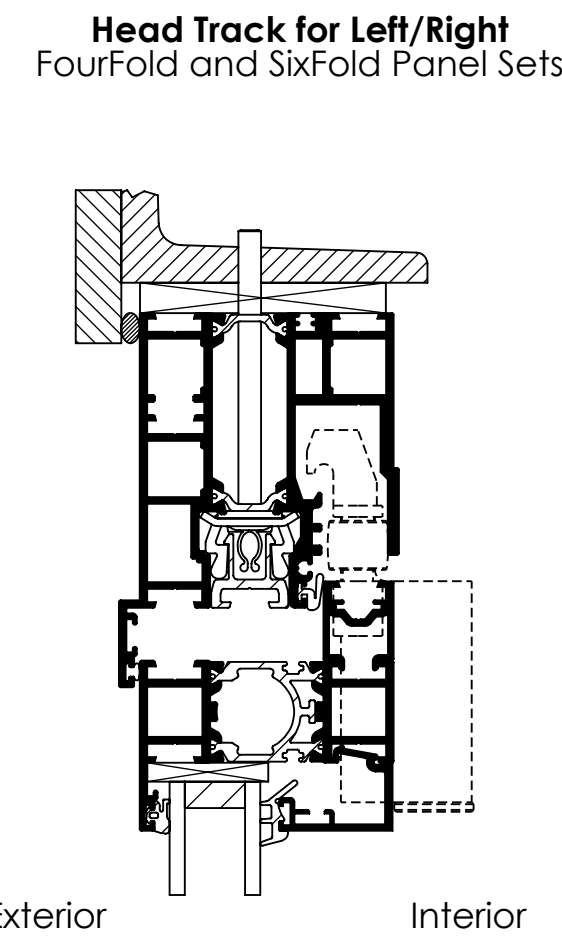

Performance Sill
(Weep slots have to be unobstructed. Details of the management of water exiting the weep slots must be designed and installed by others.)

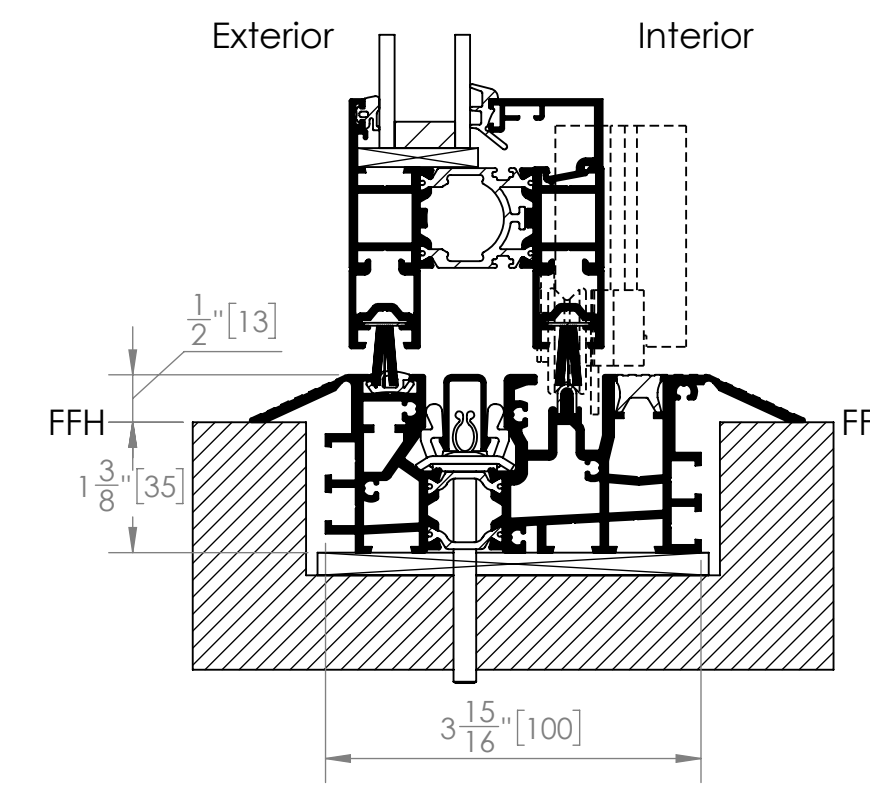
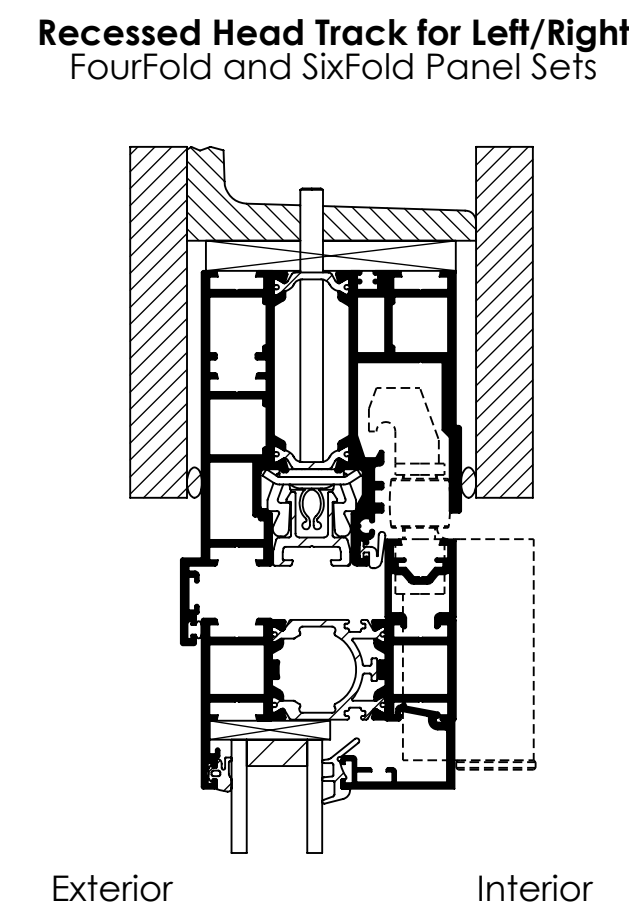

Low Profile Saddle Sill - Option 2
(If no water rating is needed.)

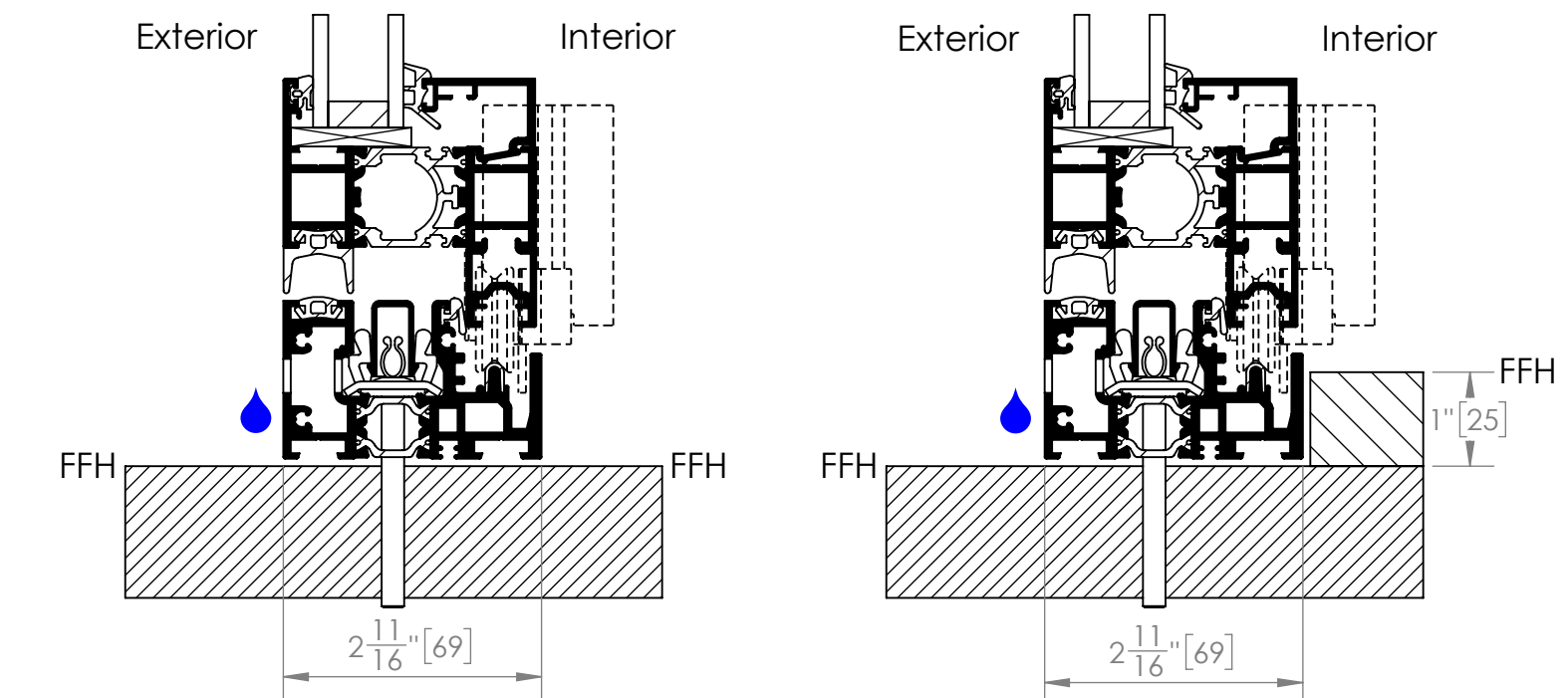

Performance Sill
(Weep slots have to be unobstructed. Details of the management of water exiting the weep slots must be designed and installed by others. If required to drain sill cavities completely, drill one additional 5/16" (8 mm) diameter weep hole on the front face of the sill 3/8" (10mm) from the bottom.)

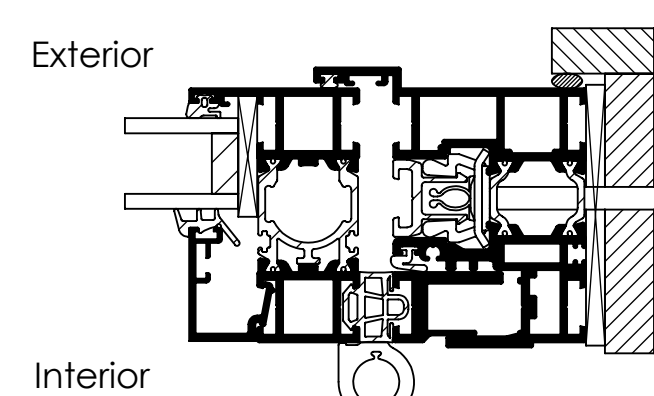

Panel Hinged at Right Side Jamb

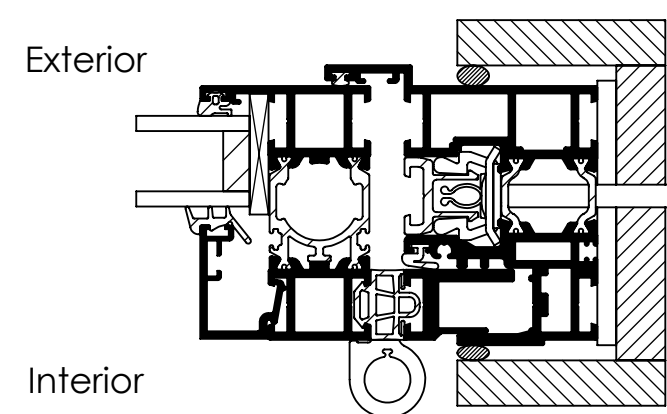

Panel Hinged at Right with Recessed Side Jamb

Low Profile Saddle Sill Option 1 Detail Drawing

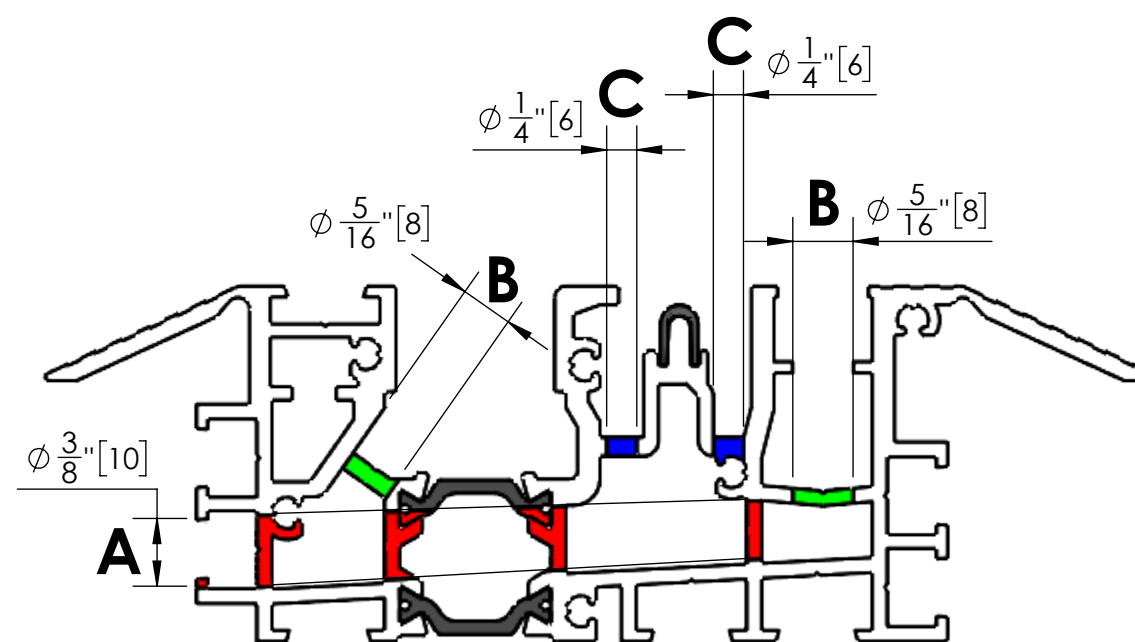

A Drill holes all the way to the back as shown at a slight angle upwards. Before creating the 3/8" (10mm) drainage hole, we recommend using a smaller drill bit to create a pilot hole.

B Drill holes as shown.

C Drill 2 holes as shown at both ends of the channel.

Location of various holes per the Low Profile Saddle Sill Option 1 Drawing

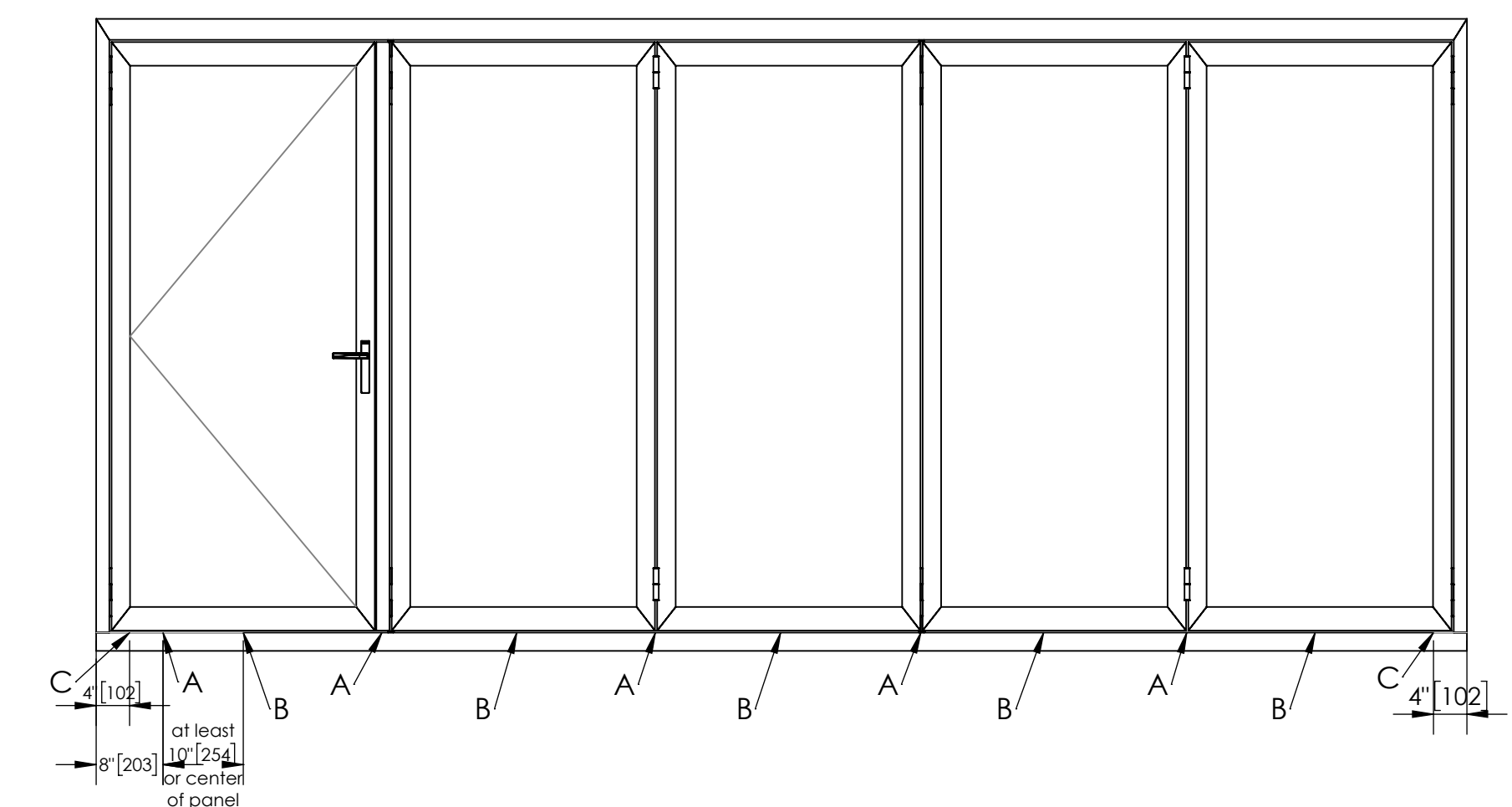

Note: **A:** Drill 3/8" (10 mm) hole in location shown.
B: Drill 5/16" (8 mm) hole in location shown.
C: Drill 1/4" (6 mm) holes at both ends in location shown.

SPECIFICATIONS AND DETAILS SUBJECT TO CHANGE WITHOUT NOTICE
©2025 NanaWall Systems, Inc.
www.nanawall.com

All appropriate water proofing and flashing details to be designed and installed by others. These should include proper sealing of all fastener holes and each end of the sill. For more information about preparing the rough opening, installation and operation of this folding system, please look at the installation and Owner's Manual for the Generation 4 Folding Glass Walls.