

Suggested Typical Installation Outward Opening Details NW Aluminum 840 and NW Reinforced 847

alternative options

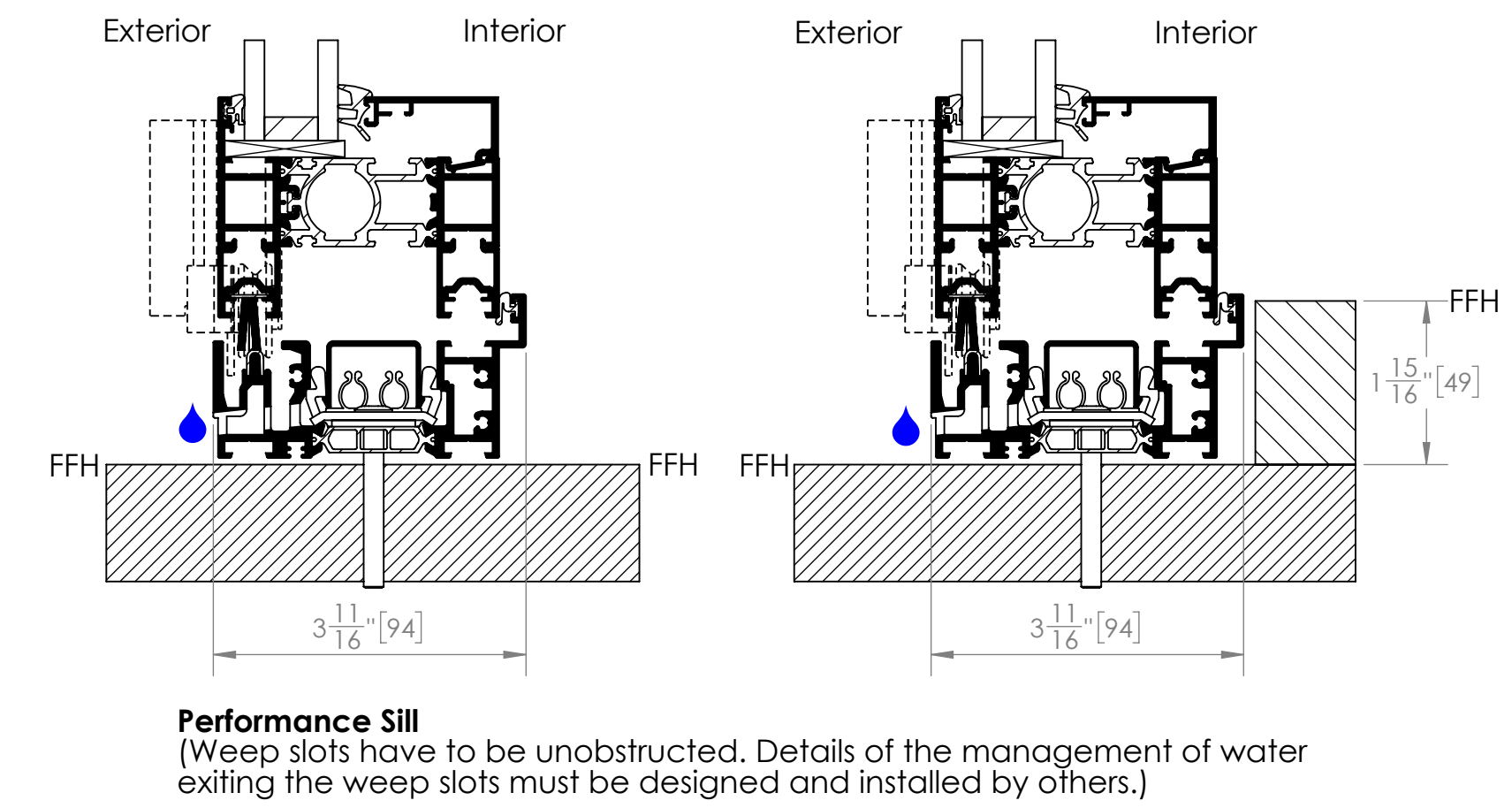
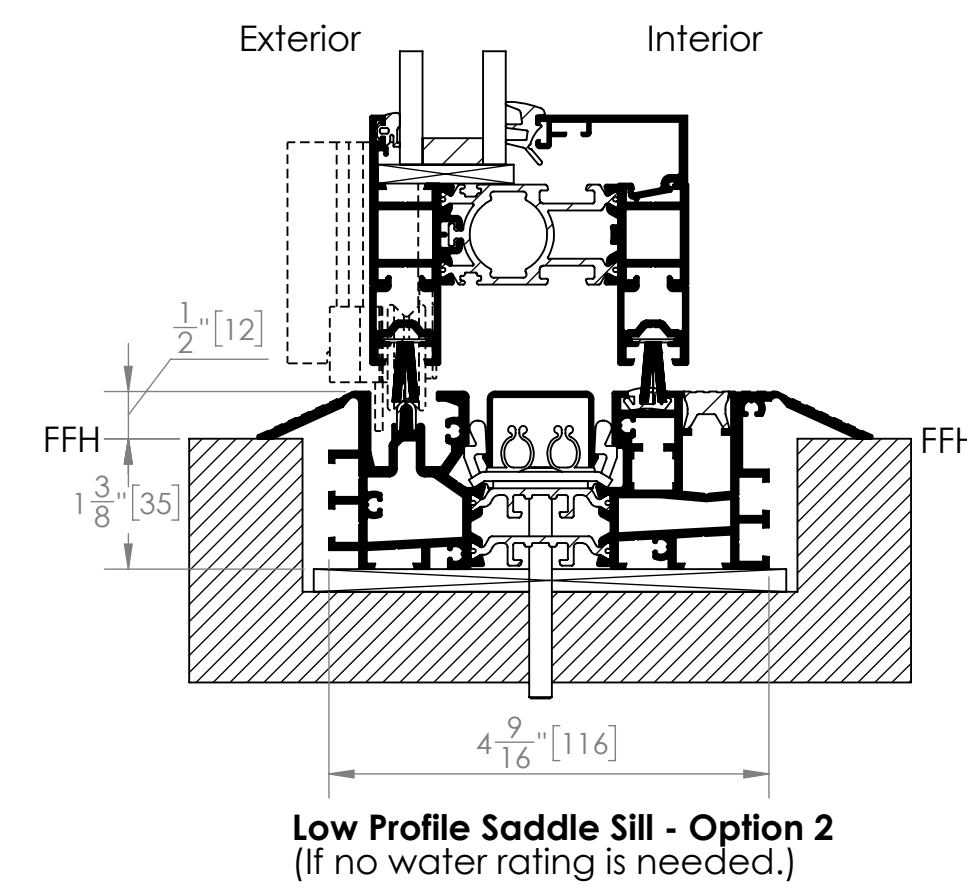
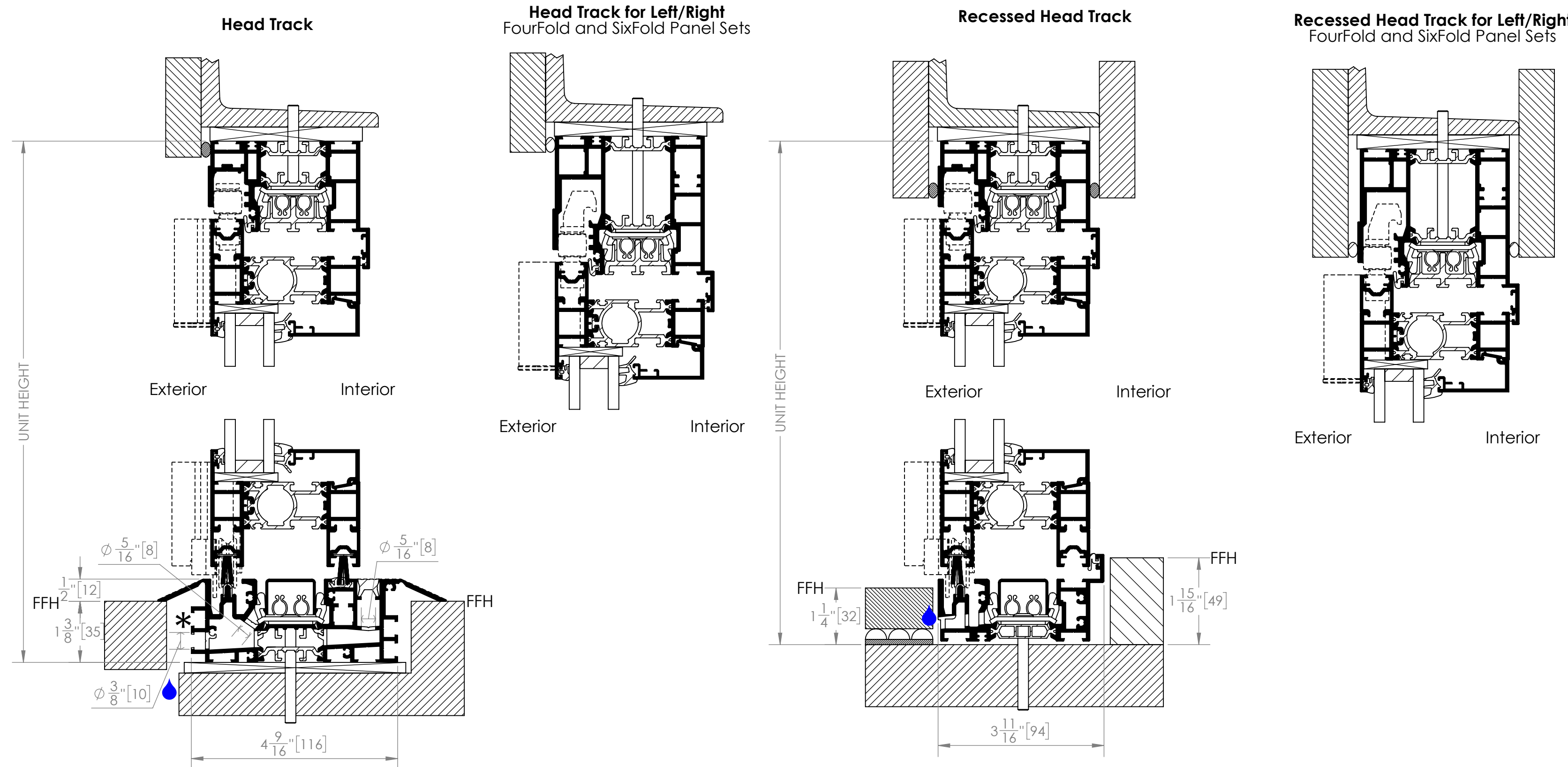

Low Profile Saddle Sill - Option 1
For any water rating, weep holes drilled in the sill and drain connections by others necessary. Please see Low Profile Saddle Sill Option 1 Detail Drawing on the right side for weep hole sizes, pattern and spacing by others

Performance Sill
(Weep slots have to be unobstructed. Details of the management of water exiting the weep slots must be designed and installed by others.)

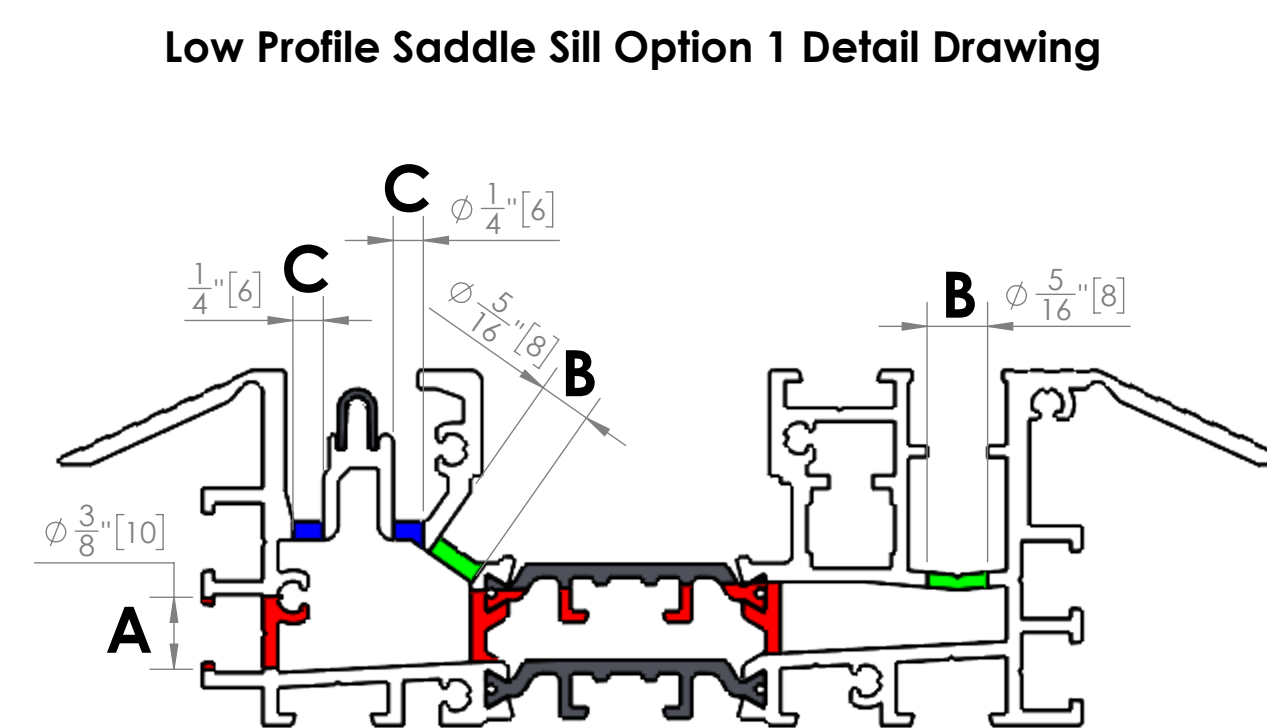
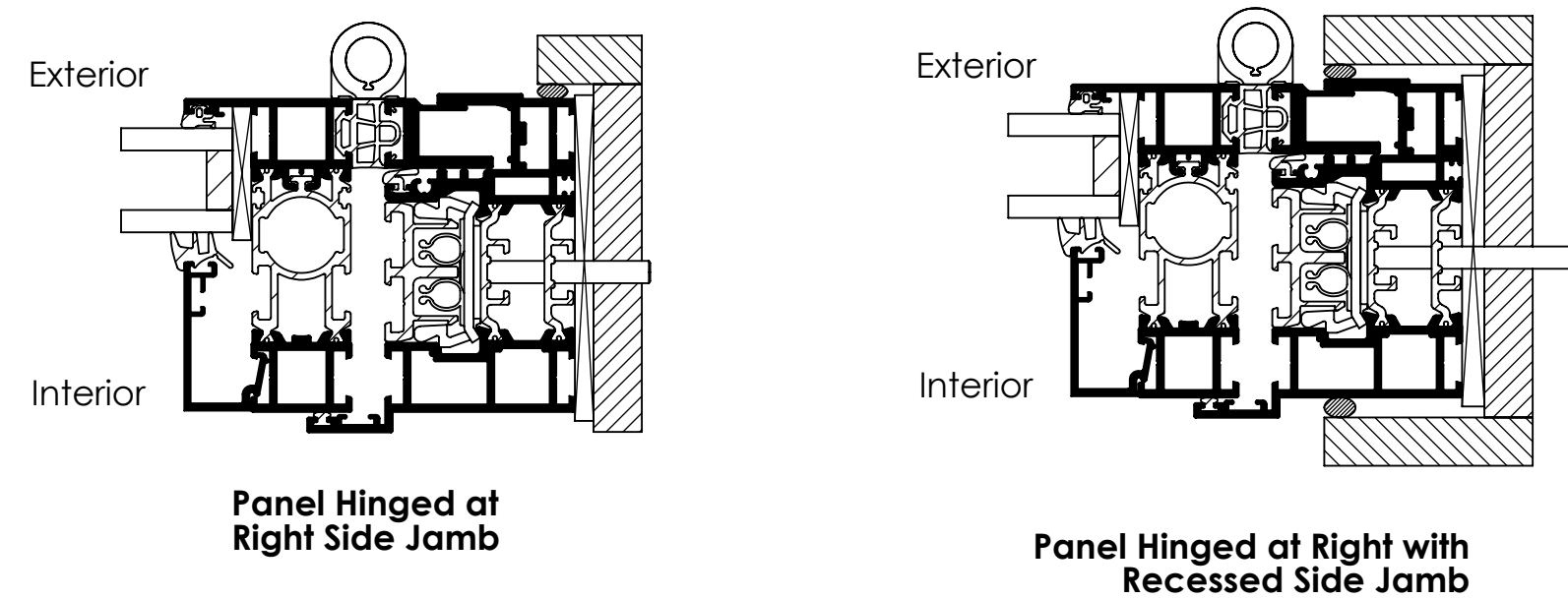

- A** Drill holes all the way to the back as shown at a slight angle upwards. Before creating the 3/8" (10mm) drainage hole, we recommend using a smaller drill bit to create a pilot hole.
- B** Drill holes as shown.
- C** Drill 2 holes as shown at both ends of the channel.

Location of various holes per the Low Profile Saddle Sill Option 1 Drawing

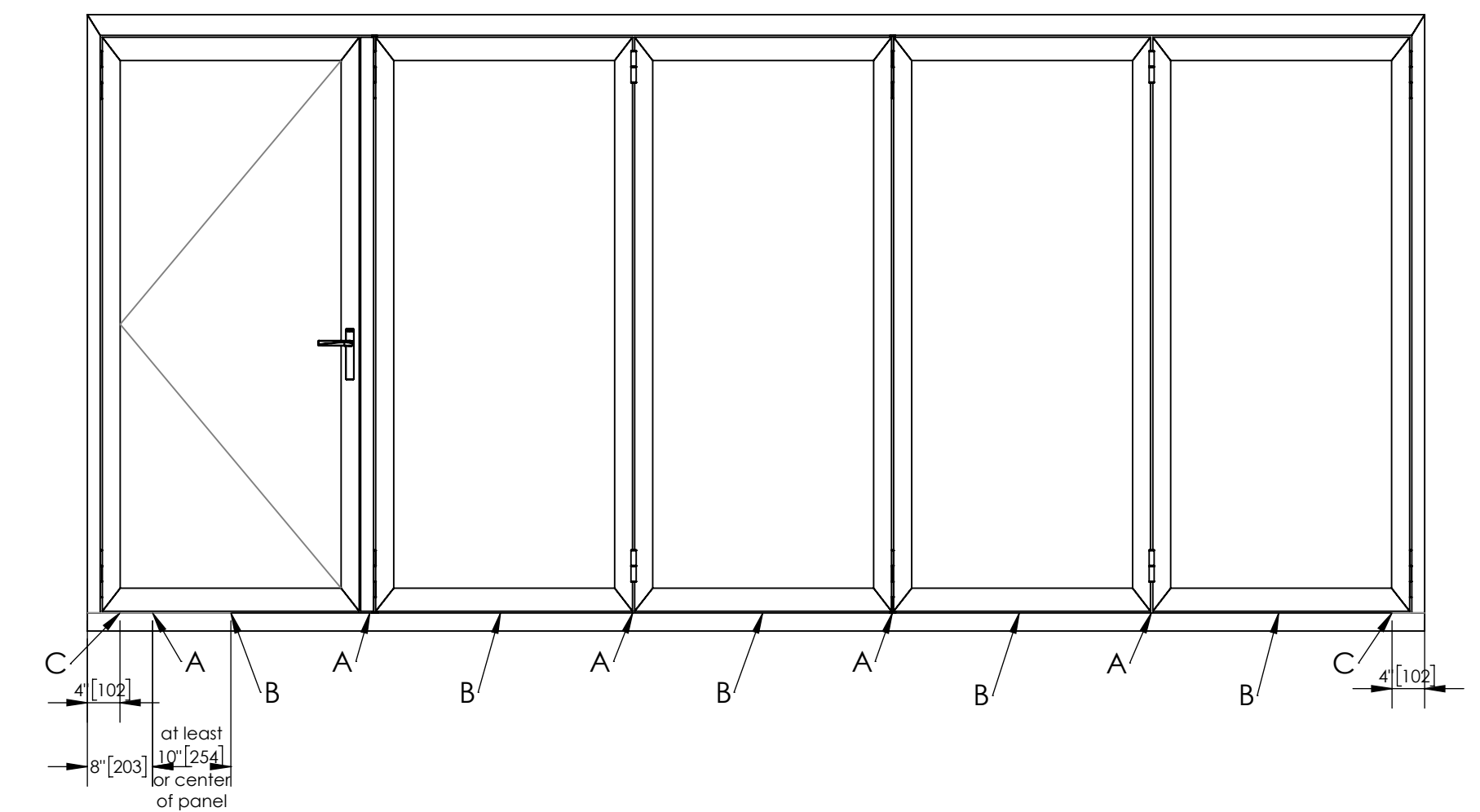

- Note: **A:** Drill 3/8" (10 mm) hole in location shown.
B: Drill 5/16" (8 mm) hole in location shown.
C: Drill 1/4" (6 mm) holes at both ends in location shown.

SPECIFICATIONS AND DETAILS SUBJECT TO CHANGE WITHOUT NOTICE
©2025 NanaWall Systems, Inc.
www.nanawall.com

All appropriate water proofing and flashing details to be designed and installed by others. These should include proper sealing of all fastener holes and each end of the sill. For more information about preparing the rough opening, installation and operation of this folding system, please look at the installation and Owner's Manual for the Generation 4 Folding Glass Walls.